

Model G1 & G4 Sprinkler Guards Model G1/S1 & G4/S3 Guards with Shields Series TY-B, TY-FRB, TY-L, and TY-FRL Sprinklers

General Description

The Model G1 & G4 Sprinkler Guards (Ref. Figure 1) are designed for use with specific types of Series TY-B, TY-FRB, TY-L, and TY-FRL Sprinklers that may be located in areas that make them susceptible to mechanical or physical damage. Table A provides compatibility details.

The Model G1/S1 & G4/S3 Sprinkler Guards with Shields (Ref. Figure 2), in addition to providing protection from mechanical or physical damage, shields the sprinkler from water spray of higher elevation sprinklers (e.g., rack storage sprinkler installations). When the G1/S1 and G4/S3 are used with the Series TY-B, TY-FRB, TY-L, and TY-FRL Sprinklers shown in Table A, the assemblies form Upright Intermediate Level Sprinklers intended for use in fire sprinkler systems designed in accordance with the standard installation rules recognized by the applicable Listing agency (i.e., UL Listing is based on NFPA requirements).

The G1 and G4 are a redesignation for the Gem F938 & F937, and the G1/S1 & G4/S3 are a redesignation for the Gem F938/Q-76 and F937/Q-75.

WARNINGS

The Model G1 & G4 Sprinkler Guards and G1/S1 & G4/S3 Sprinkler Guards with Shields described herein must be installed and maintained in compliance with this document, as well as with the applicable standards of the National Fire Protection Association, in addition to the standards of any other authorities having jurisdiction. Failure to do so may impair the integrity of these devices.

The owner is responsible for maintaining their fire protection system and devices in proper operating condition. The installing contractor or manufacturer should be contacted relative to any questions.

Technical Data

Approvals

UL and C-UL Listed. FM Approved. (Refer to Table A)

Finishes

Red Painted and Zinc Chromate

Physical Characteristics

Welded assembly fabricated from carbon steel

Design Criteria

In accordance with the requirements of the NFPA, sprinkler guards shall be listed. Guards are only listed for use with specified sprinklers; therefore, the G1, G4, G1/S1, and G4/S3 must only be used with the Series TY-B, TY-FRB, TY-L, and TY-FRL Sprinklers shown in Table A.

Installation

The Models G1, G4, G1/S1, and G4/S3 are to be installed as follows:

Step 1. The G1, G4, G1/S1, or G4/S3 is to be mounted on the sprinkler after the sprinkler has been installed in accordance with its applicable technical data sheet.

Step 2. With the Clips loose, first spread the two halves of the Sprinkler Guard just enough to pass by the sprinkler deflector from the side. Then, once again spread the two halves of the Sprinkler Guard just enough to pass over the sprinkler "thread relief" or "wrenching area", as applicable, portion of the sprinkler. (Refer to Table A, as well as Figures 1 and 2.)

Step 3. With the Sprinkler Guard positioned on the "thread relief" or "wrenching area" portion of the sprinkler, as applicable, engage the Clips and then slide the Clips until they



G1



G4



G1/S1



G4/S3

| SERIES SPRINKLER | TFP SIN | GEM SIN | STAR SIN | SPRINKLER TYPE | SPRINKLER K-FACTOR | MOUNTING LOCATION | GUARD MODEL (APPROVALS) | GUARD WITH SHIELD MODEL (APPROVALS) |
|------------------|---------|---------|----------|----------------|--------------------|-------------------|-------------------------|-------------------------------------|
| TY-B | TY1151 | G7530 | — | Upright | 2.8 | Thread Relief | G1 (1) | N/A |
| | TY1251 | G7531 | — | Pendent | 2.8 | Thread Relief | G1 (1) | N/A |
| | TY3151 | G7570 | — | Upright | 5.6 | Thread Relief | G1 (1, 2) | G1/S1 (1) |
| | TY3251 | G7571 | — | Pendent | 5.6 | Thread Relief | G1 (1, 2) | N/A |
| | TY4851 | G7560 | — | Upright | 8.0 (1/2" NPT) | Thread Relief | G1 (1, 2) | N/A |
| | TY4951 | G7561 | — | Pendent | 8.0 (1/2" NPT) | Thread Relief | G1 (1, 2) | N/A |
| | TY4151 | G7590 | — | Upright | 8.0 (3/4" NPT) | Thread Relief | G1 (1, 2) | G1/S1 (1) |
| | TY4251 | G7591 | — | Pendent | 8.0 (3/4" NPT) | Thread Relief | G1 (1, 2) | N/A |
| | TY3351 | G7578 | — | HSW | 5.6 | Thread Relief | G4 (1) | N/A |
| | TY3451 | G7575 | — | VSW | 5.6 | Thread Relief | G4 (1) | N/A |
| TY-FRB | TY1131 | G7330 | — | Upright | 2.8 | Thread Relief | G1 (1) | N/A |
| | TY1231 | G7331 | — | Pendent | 2.8 | Thread Relief | G1 (1) | N/A |
| | TY3131 | G7370 | — | Upright | 5.6 | Thread Relief | G1 (1, 2) | G1/S1 (1) |
| | TY3231 | G7371 | — | Pendent | 5.6 | Thread Relief | G1 (1, 2) | N/A |
| | TY4131 | G7390 | — | Upright | 8.0 (3/4" NPT) | Thread Relief | G1 (1, 2) | G1/S1 (1) |
| | TY4231 | G7391 | — | Pendent | 8.0 (3/4" NPT) | Thread Relief | G1 (1) | N/A |
| | TY3331 | G7378 | — | HSW | 5.6 | Thread Relief | G4 (1) | N/A |
| | TY3431 | G7375 | — | VSW | 5.6 | Thread Relief | G4 (1) | N/A |
| TY-L | TY3111 | G3111 | S1800 | Upright | 5.6 | Wrench Area | G1 (2) & G4 (1) | G4/S3 (1) |
| | TY3211 | G3112 | S1801 | Pendent | 5.6 | Wrench Area | G1 (2) & G4 (1) | N/A |
| | TY3311 | G3113 | S1803 | HSW | 5.6 | Wrench Area | — | N/A |
| | TY4811 | — | S1805 | Upright | 8.0 (1/2" NPT) | Wrench Area | G4 (1, 2) | G4/S3 (1) |
| | TY4911 | — | S1806 | Pendent | 8.0 (1/2" NPT) | Wrench Area | G4 (1) | N/A |
| | TY4111 | G3101 | S1810 | Upright | 8.0 (3/4" NPT) | Wrench Area | G4 (1, 2) | G4/S3 (1) |
| | TY4211 | G3102 | S1811 | Pendent | 8.0 (3/4" NPT) | Wrench Area | G4 (1) | N/A |
| TY-FRL | TY1121 | G8973 | S1879 | Upright | 2.8 | Wrench Area | G4 (1) | N/A |
| | TY1221 | G8971 | S1880 | Pendent | 2.8 | Wrench Area | G4 (1) | N/A |
| | TY3121 | G8974 | S1864 | Upright | 5.6 | Wrench Area | G4 (1, 2) | G4/S3 (1) |
| | TY3221 | G8972 | S1865 | Pendent | 5.6 | Wrench Area | G4 (1) | N/A |
| | TY3321 | G8946 | S1878 | HSW | 5.6 | Wrench Area | G4 (1) | N/A |
| | TY4121 | G8174 | S1866 | Upright | 8.0 (3/4" NPT) | Wrench Area | G4 (1, 2) | G4/S3 (1) |
| | TY4221 | G8172 | S1867 | Pendent | 8.0 (3/4" NPT) | Wrench Area | G4 (1) | N/A |

APPROVALS & NOTES:

1. Listed by Underwriters Laboratories Inc.
 2. Approved by Factory Mutual Research Corporation.
- N/A Not Applicable for noted sprinkler.
 — No SIN, Listing or Approval

TABLE A — LABORATORY LISTINGS AND APPROVALS

seat against the Base to complete the installation as shown in Figures 1 and 2.

To help assist with the sliding of the Clips the Guard Installation Tool may be used as shown in Figure 3. In addition, pliers can be used to facilitate the final seating of the Clips.

NOTES

The Clips must seat against the Base in order to be considered fully seated and in order to complete the installation.

The G1, G4, G1/S1, and G4/S3 may be located in any position relative to the sprinkler frame arms.

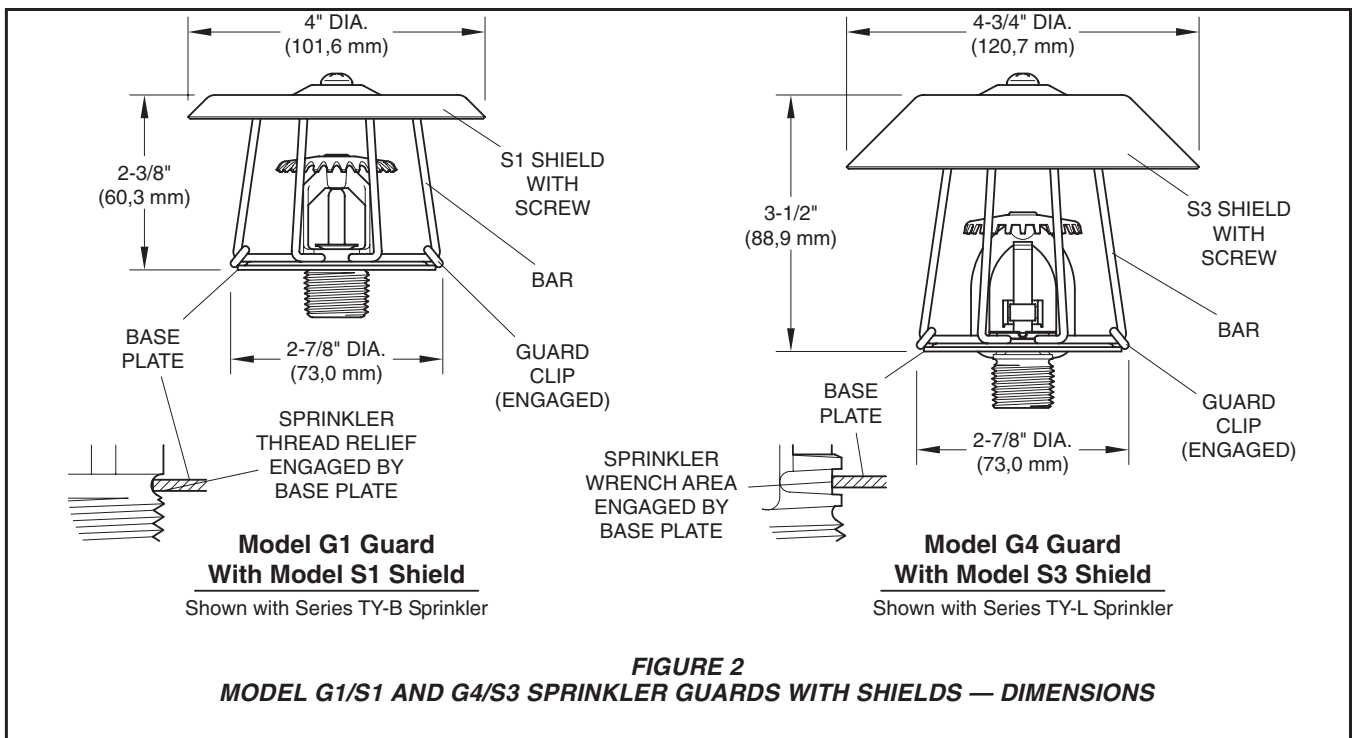
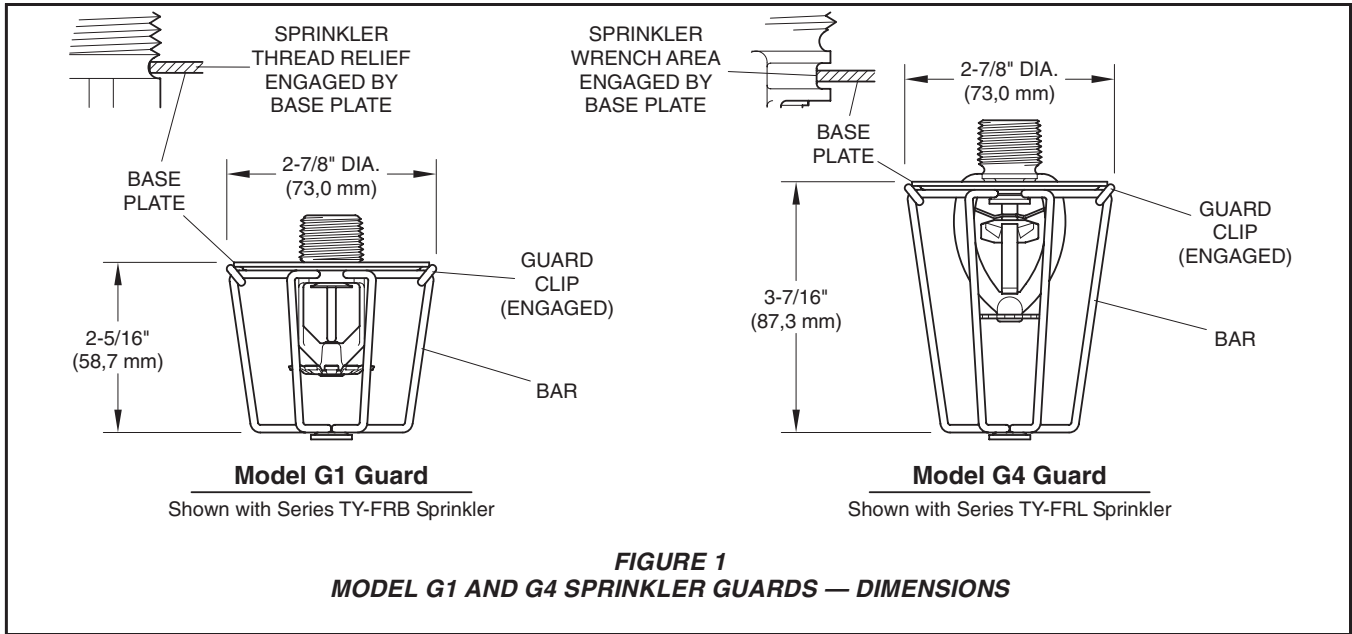

Care and Maintenance

The Models G1, G4, G1/S1, and G4/S3 do not require any regularly scheduled maintenance; however, proper installation of the Sprinkler Guards should be verified during the annual visual inspection of the sprinklers.

The owner is responsible for the inspection, testing, and maintenance of

their fire protection system and devices in compliance with this document, as well as with the applicable standards of the National Fire Protection Association (e.g., NFPA 25), in addition to the standards of any other authorities having jurisdiction. The installing contractor or sprinkler manufacturer should be contacted relative to any questions.

It is recommended that automatic sprinkler systems be inspected, tested, and maintained by a qualified Inspection Service.

Limited Warranty

Products manufactured by Tyco Fire Products are warranted solely to the original Buyer for ten (10) years against defects in material and workmanship when paid for and properly installed and maintained under normal use and service. This warranty will expire ten (10) years from date of shipment by Tyco Fire Products. No warranty is given for products or

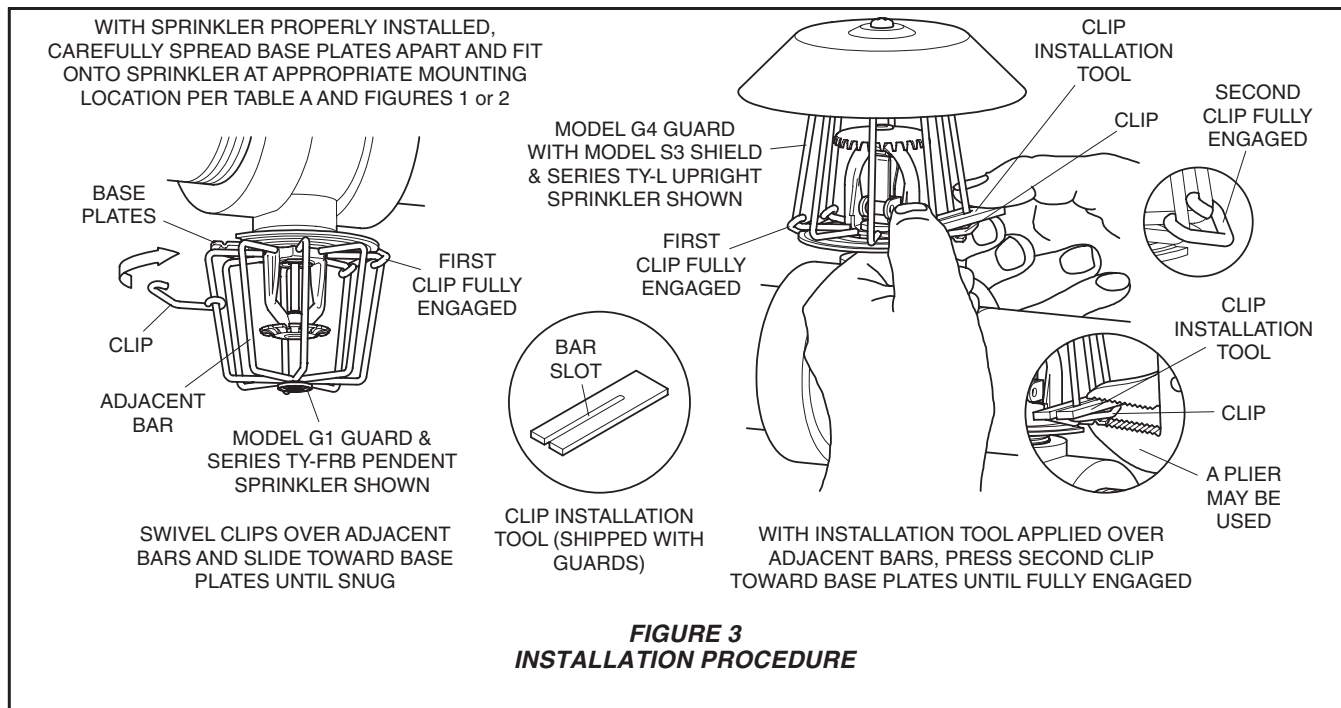

**FIGURE 3
INSTALLATION PROCEDURE**

components manufactured by companies not affiliated by ownership with Tyco Fire Products or for products and components which have been subject to misuse, improper installation, corrosion, or which have not been installed, maintained, modified or repaired in accordance with applicable Standards of the National Fire Protection Association, and/or the standards of any other Authorities Having Jurisdiction. Materials found by Tyco Fire Products to be defective shall be either repaired or replaced, at Tyco Fire Products' sole option. Tyco Fire Products neither assumes, nor authorizes any person to assume for it, any other obligation in connection with the sale of products or parts of products. Tyco Fire Products shall not be responsible for sprinkler system design errors or inaccurate or incomplete information supplied by Buyer or Buyer's representatives.

IN NO EVENT SHALL TYCO FIRE PRODUCTS BE LIABLE, IN CONTRACT, TORT, STRICT LIABILITY OR UNDER ANY OTHER LEGAL THEORY, FOR INCIDENTAL, INDIRECT, SPECIAL OR CONSEQUENTIAL DAMAGES, INCLUDING BUT NOT LIMITED TO LABOR CHARGES, REGARDLESS OF WHETHER TYCO FIRE PRODUCTS WAS INFORMED ABOUT THE POSSIBILITY OF SUCH DAMAGES, AND IN NO EVENT SHALL TYCO FIRE PRODUCTS' LIABILITY EXCEED AN AMOUNT EQUAL TO THE SALES PRICE.

THE FOREGOING WARRANTY IS MADE IN LIEU OF ANY AND ALL OTHER WARRANTIES EXPRESS OR

IMPLIED, INCLUDING WARRANTIES OF MERCHANTABILITY AND FITNESS FOR A PARTICULAR PURPOSE.

Ordering Procedure

Contact your local distributor for availability.

G1 Sprinkler Guard:
Specify: Model G1 Sprinkler Guard having a (specify) finish, P/N (specify).

Red Painted P/N 56-938-1-001
Zinc Chromate P/N 56-938-9-001

G4 Sprinkler Guard:
Specify: Model G4 Sprinkler Guard having a (specify) finish, P/N (specify).

Red Painted P/N 56-937-1-001
Zinc Chromate P/N 56-937-9-001

G1/S1 Guard with Shield:
Specify: Model G1/S1 Sprinkler Guard with Shield having a (specify) finish, P/N (specify).

Red Painted P/N 56-938-1-066
Zinc Chromate P/N 56-938-9-066

G4/S3 Guard with Shield:
Specify: Model G4/S3 Sprinkler Guard with Shield having a (specify) finish, P/N (specify).

Red Painted P/N 56-937-1-066
Zinc Chromate P/N 56-937-9-066

Additional* Clip Installation Tool:
Specify: Clip Installation Tool for G1 & G4 Sprinkler Guards, P/N (56-000-8-597).

* The Clip Installation Tool is included with orders in original cartons.