

Model ACC-1 Dry Pipe Valve Accelerator External Resetting Quick Opening Device For Dry Pipe Valves

General Description

The Model ACC-1 Accelerator is a quick opening device intended for attachment to the Tyco Fire & Building Products, 2-1/2, 3, 4 or 6 inch Model DPV-1 Dry Pipe Valve. The Model ACC-1 Accelerator reduces the time for valve operation following the operation of one or more automatic sprinklers.

The Model ACC-1 Accelerator automatically adjusts to both small and slow changes in system pressure, but trips when there is a rapid and steady drop in pressure (as in the case of a sprinkler operation). Upon tripping, the Accelerator transmits system air pressure to the intermediate chamber of the Model DPV-1 Dry Pipe Valve. This neutralizes the differential pressure holding the Model DPV-1 Dry Pipe Valve closed and permits it to open.

The Model ACC-1 Accelerator has a unique, positive action, internal anti-flood device and a ball float which combine to prevent water and water borne debris from entering the more sensitive operating areas of the accelerator. The anti-flood device seals and latches immediately upon operation of the Model ACC-1 Accelerator without waiting for a pressure build-up in the intermediate chamber of the dry pipe valve. The latching feature keeps the anti-flood device sealed, even while the system is being drained. The ball float seals the pilot chamber inlet port if there is an inadvertent trip of the dry pipe valve, due for example, to an air compressor failure combined with a slow loss in system air pressure due to a leak.

The Model ACC-1 Dry Pipe Valve Accelerator is a direct replacement for the Central Model B, Gem Model F311, and Star Model S430. Contact the Technical Services Department for information concerning the use of the

ACC-1 for use with dry pipe valves other than the Model DPV-1.

WARNING

The Model ACC-1 Dry Pipe Valve Accelerator described herein must be installed and maintained in compliance with this document, as well as with the applicable standards of the National Fire Protection Association, in addition to the standards of any other authorities having jurisdiction. Failure to do so may impair the performance of this device.

The owner is responsible for maintaining their fire protection system and devices in proper operating condition. The installing contractor or sprinkler manufacturer should be contacted with any questions.



Design Data

The connection to the system piping, Figure 4, must be located so that drain back water will not flow into the Accelerator piping and it must be located at a point above the maximum expected level of the drain back/condensate water.

If the connection is made to the riser, it must be located at least two feet above the level of the dry pipe valve. Connections to a feed or cross main must be made either to the side or top of the main.

NOTES

Failure to follow the above instructions can result in accidental tripping due to closure of the ball float.

Quick operation of the Accelerator does not ensure that the fire protection system will meet the water delivery time requirement of the authority having jurisdiction (following opening of the Inspector's Test Connection). The sprinkler system designer needs to be aware that water delivery time is primarily determined by the configuration and volume of the piping network, system air pressure at time of Accelerator trip, and water supply characteristics.

Technical Data

Approvals

UL and ULC Listed. FM and LPCB Approved.

Maximum Working Water Pressure
250 psi (17,2 bar)

Maximum Working Air Pressure
70 psi (4,8 bar)

Pressure Decay For Trip
1 psi/min (0,07 bar/min)

Physical Characteristics

Body components constructed of alodine coated aluminum alloy with austenitic series stainless steel internal components. Seals are EPDM and silicone.

Patents

U.S.A. 4,570,719
United Kingdom 2,159,406

Operation

The Inlet Chamber of the Accelerator, Figure 1, is pressurized via its connection to the system (at a point above the maximum expected level of drain back water). The Pilot Chamber is, in turn, pressurized through its inlet port which is formed by the annular opening around the lower tip of the Anti-Flood Valve. As the Pilot Chamber increases in pressure, the Differential Chamber is pressurized through the Restriction.

The Accelerator is in its set position while it is being pressurized as well as after the Inlet, Pilot Chamber and Differential Chamber pressures have equalized. When in the Set position, the Outlet Chamber is sealed off by the Exhaust Valve which is held against its seat by a combination of the Spring pushing up against the Lever and the net downward force exerted by the pressure in the Pilot Chamber.

Both small and slow changes in system pressure are accommodated by flow through the Restriction. When, however, there is a rapid and steady drop in system (i.e., Inlet and Pilot Chamber) pressure, the pressure in the Differential Chamber reduces at a substantially lower rate. This condition creates a net downward force on the Plunger which rotates the Lever. As the Lever is rotated, Figure 2, the Relief Valve is raised out of the Relief Port and the Anti-Flood Valve is depressed downward into the Pilot Chamber Inlet Port, venting the Pilot Chamber.

The system pressure in the Inlet Chamber then forces (raises) the Exhaust Valve off its seat. This continues the rotation of the Lever into the tripped (latched) position, Figure 2. As the Exhaust Valve is raised off its seat, system pressure is transmitted to the intermediate chamber of the dry pipe valve which neutralizes the differential pressure holding the valve closed.

Following the dry pipe valve trip, major water borne debris is prevented from entering the Accelerator (via the connection to the system piping) by the Strainer located at its Inlet. Water and any fine water borne debris such as silt is prevented from entering the Pilot Chamber by virtue of the Anti-Flood Valve having sealed off its inlet port. The Check Valve located downstream of the Accelerator Outlet prevents any water borne debris from entering the Accelerator via the connection to the intermediate chamber of the dry pipe valve.

After the accelerator/dry pipe valve has tripped and the sprinkler system

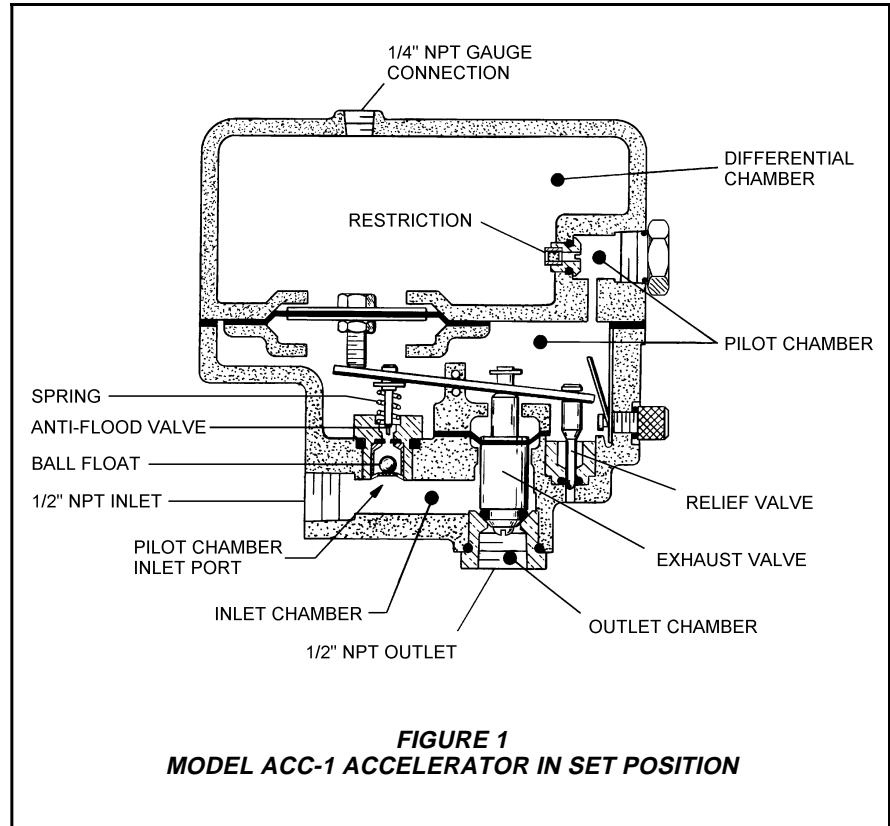

**FIGURE 1
MODEL ACC-1 ACCELERATOR IN SET POSITION**

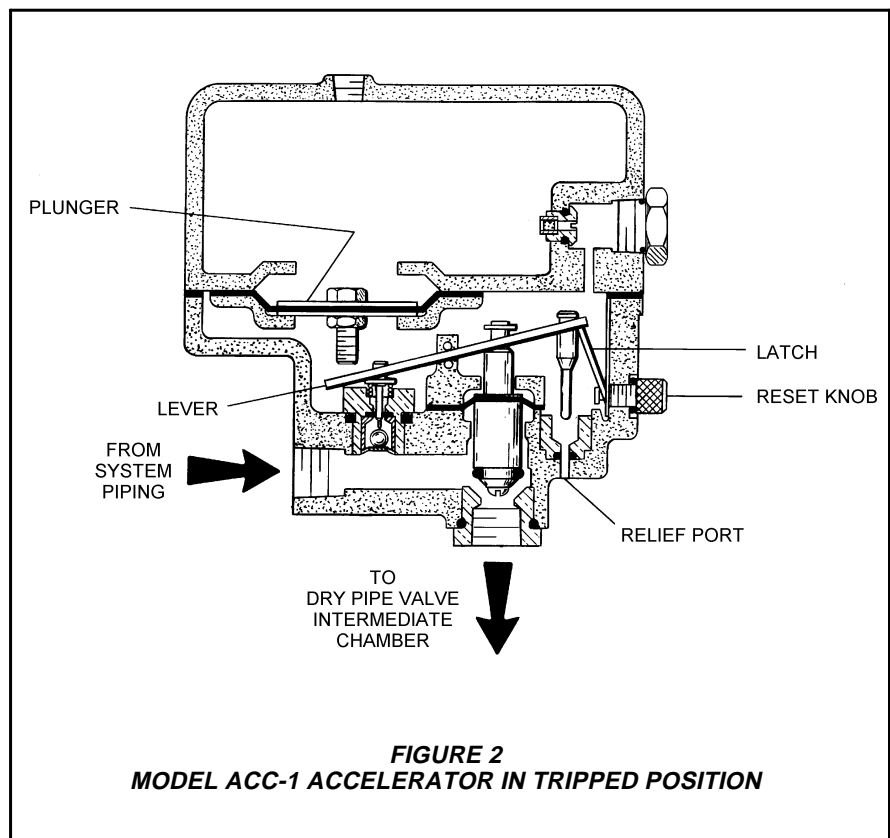

**FIGURE 2
MODEL ACC-1 ACCELERATOR IN TRIPPED POSITION**

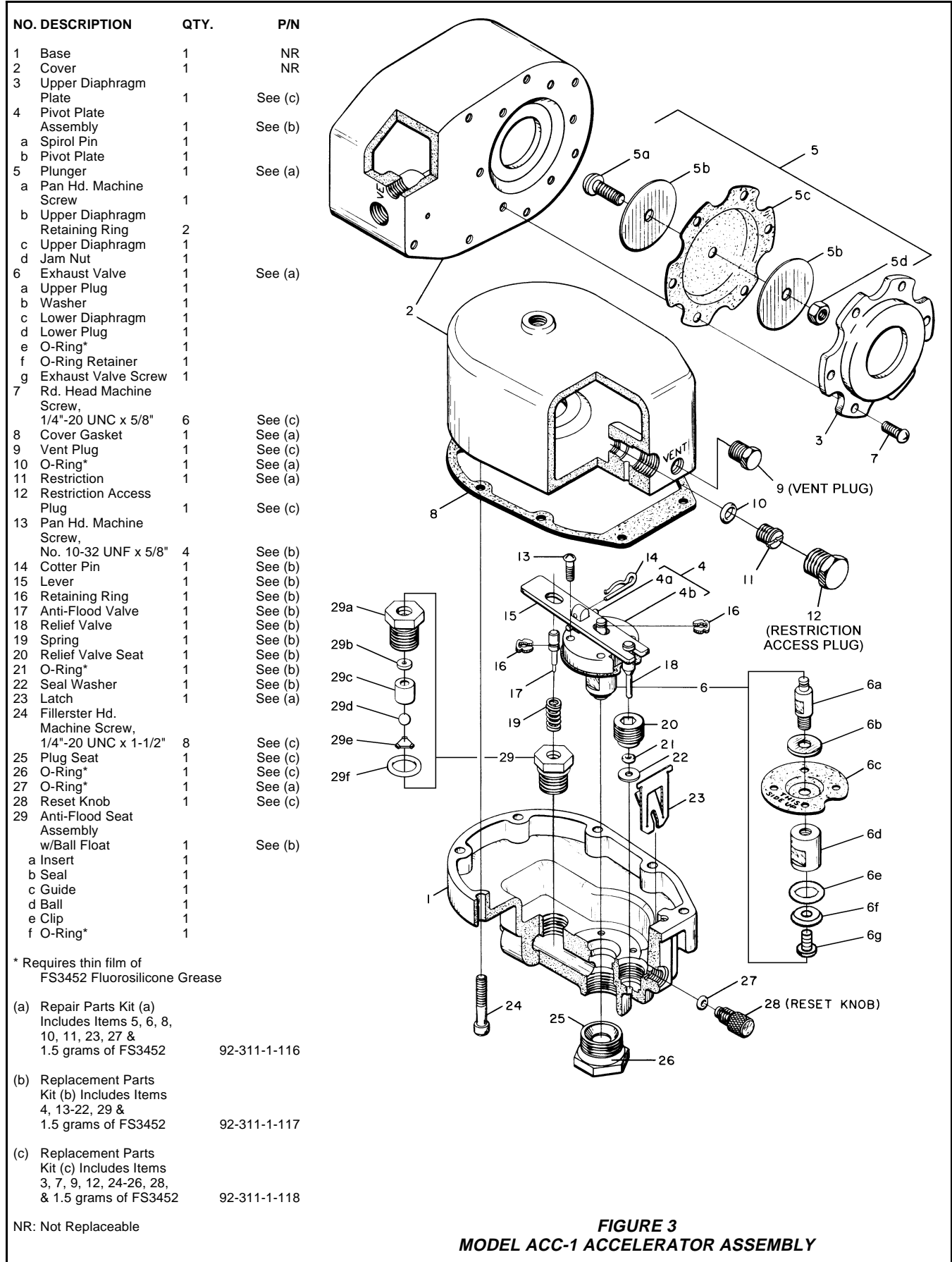

FIGURE 3
MODEL ACC-1 ACCELERATOR ASSEMBLY

NO	DESCRIPTION	QTY	P/N
1	250 psi/ 1750 kPa Air Pressure Gauge	1	92-343-1-012
2	1/2" Y-Strainer	1	52-353-1-005

NO	DESCRIPTION	QTY	P/N
3	1/2" Ball Valve	1	46-050-1-004
4	1/2" Swing Check Valve	1	46-049-1-004
5	1/2" Union	2	CH

NO	DESCRIPTION	QTY	P/N
6	1/2" 90° Elbow	3	CH
7	1/2" x 1-1/2" Nipple	6	CH
8	1/2" x 3" Nipple	1	CH
9	1/2" x 3-1/2" Nipple	1	CH
10	1/2" x 5-1/2" Nipple	1	CH

* In accordance with the 2007 edition of NFPA 13, 7.2.4.4, the Accelerator Control Valve shall be supervised. Where a signaling service is to be utilized, replace the Ball Valve with a BVS-1/2" electrically supervised control valve.

CH: Common Hardware

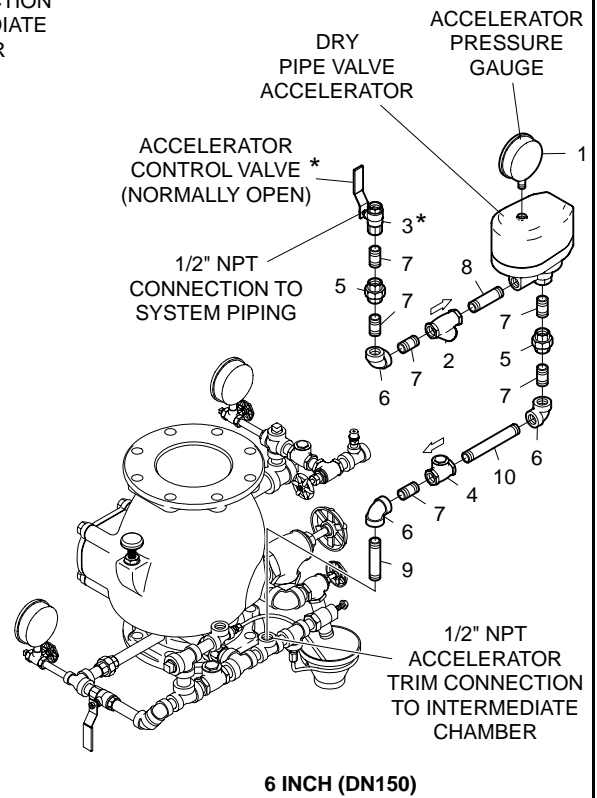
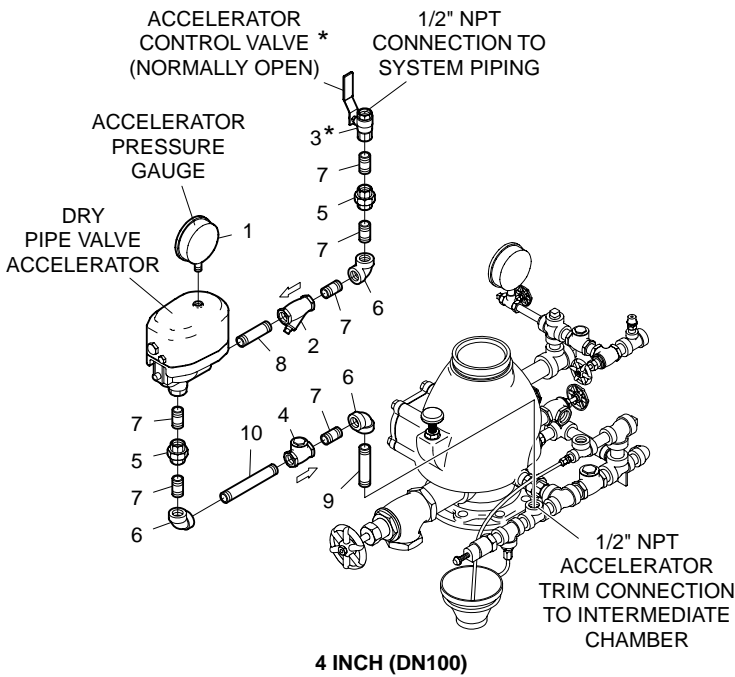
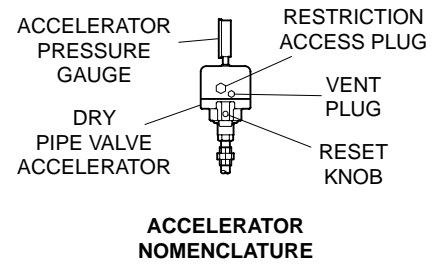
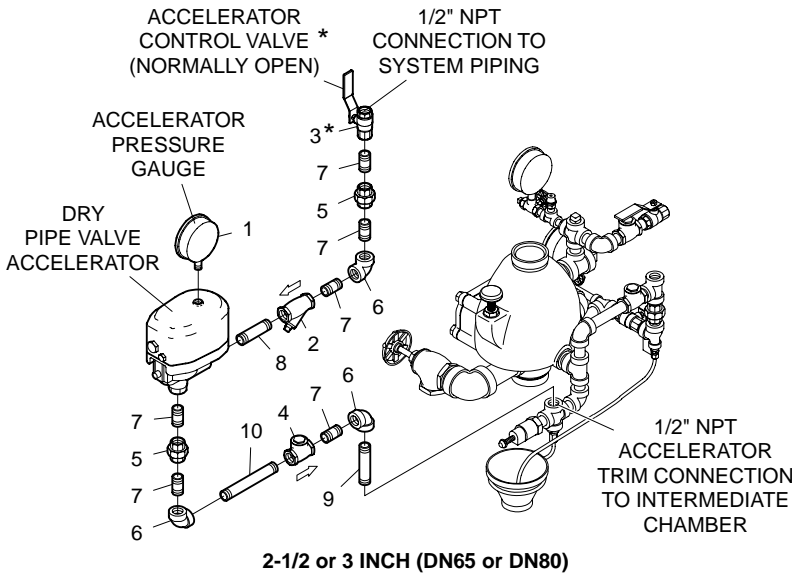

FIGURE 4
MODEL ACC-1 DRY PIPE VALVE ACCELERATOR TRIM
FOR 2-1/2, 3, 4, AND 6 INCH MODEL DPV-1 DRY PIPE VALVES

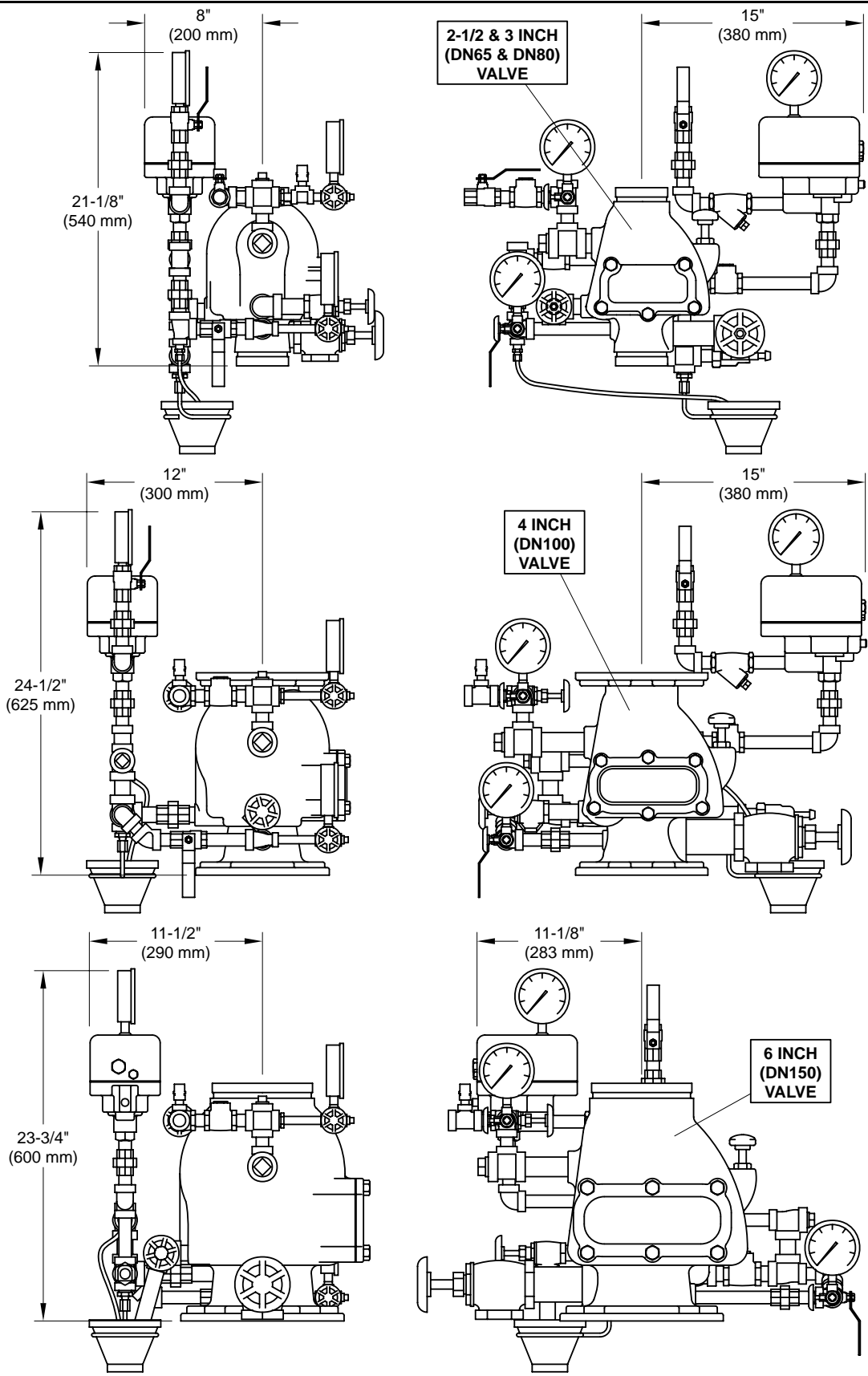

FIGURE 5
MODEL ACC-1 DRY PIPE VALVE ACCELERATOR TRIM
— INSTALLATION DIMENSIONS —

has been drained, the piping from the system to the Accelerator must also be drained and the Accelerator reset/inspected according to the instructions given in the Setting Procedure Section.

The rate-of-flow through the Restriction has been set such that the Model ACC-1 Accelerator provides the maximum practical sensitivity to a loss in system pressure due to a sprinkler operation while still being capable of automatically compensating for normal variations in system pressure such as are caused by environmental temperature changes. A test for verifying that the rate-of-flow through the Restriction is within the range for optimum Accelerator performance is given in the Setting Procedure Section.

Installation

The Model ACC-1 Accelerator must be installed in accordance with the following instructions:

NOTE

Failure to follow these instructions can result in flooding of the Accelerator and accidental tripping due to closure of the ball float.

Step 1. The Accelerator must be positioned vertically and trimmed per the arrangement shown in Figure 4. Apply pipe thread sealant sparingly to male threads only.

Step 2. The Strainer located at the Accelerator Inlet must be installed with its arrow pointed towards the Accelerator.

Step 3. The Check Valve located in the line between the Accelerator Outlet and the intermediate chamber of the dry pipe valve must be installed horizontally with its arrow pointed in the direction of flow to the intermediate chamber.

Step 4. The connection to the system piping must be located so that drain back water will not flow into the Accelerator piping and it must be located at a point above the maximum expected level of the drain back/condensate water.

If the connection is made to the riser, it must be located at least two feet above the level of the dry pipe valve priming water. Connections to a feed or cross main must be made either to the side or top of the main.

Step 5. The accelerator/dry pipe valve combination must be installed in a heated enclosure which is maintained at a minimum temperature of

Pressure, psi	Minimum, sec.	Maximum, sec.
20	24	160
25	18	116
30	15	92
40	10	60
50	8	48
60	6	36

**TABLE A
DIFFERENTIAL CHAMBER FILL TIMES TO 10 PSI**

40°F/4°C. Heat tracing is not permitted.

Step 6. Close the Accelerator Control Valve until the Model ACC-1 Accelerator is ready to be placed in service.

The Accelerator Control Valve must be closed during hydrostatic testing of the system in order to prevent damage to the Ball Float. After the system is hydrostatically tested and drained, the Accelerator connection to the system must be independently drained through the Strainer clean-out plug by first removing the Strainer clean-out plug and then opening the Accelerator Control Valve to vent the line.

Setting Procedure

The Model ACC-1 Accelerator and Dry Pipe Valve must be reset and restored to service as soon as possible after an operation. Follow the procedure indicated below.

Step 1. Close the system main control valve, the air supply control valve (to the system) and the Accelerator Control Valve.

Step 2. Open the Inspector's Test Connection and then open the main drain valve as well as all auxiliary (low point) drains.

Step 3. After the system has been drained, close the Inspector's Test Connection and all auxiliary drain valves. Leave the main drain valve open.

Step 4. Set the dry pipe valve in accordance with the instructions given in the appropriate technical data sheet. Restore normal system air pressure. Leave the main control valve closed and the main drain valve open.

Step 5. While holding the plunger of the dry pipe valve's automatic drain valve depressed, partially open the Accelerator Control Valve, and allow the water in the Accelerator piping to blow out. After water spray stops discharging, close the Accelerator Control Valve and then release the

plunger. (*This instruction does not apply when the Model ACC-1 Accelerator is being set for the first time, since the Accelerator is shipped in the set position. Proceed to Step 6.*)

Step 6. Clean out the Strainer at the Accelerator Inlet.

NOTE

A clogged strainer can prevent the Accelerator from properly tripping the dry pipe valve.

Step 7. Slowly remove the Vent Plug located in the front of the Accelerator Cover and bleed off any residual air pressure in the Differential Chamber.

Step 8. Unscrew (counter-clockwise rotation) the knurled Reset Knob at the front of the Accelerator until it resists further turning. A click, which is the sound of the Lever snapping back into the Set Position, may be heard. Screw the Reset Knob back in until it is finger tight.

NOTE

Do not wrench on the reset Knob, since damage may result. The Reset Knob will turn with finger torque only.

Step 9. Replace the Vent Plug.

Step 10. Verify that the system air pressure has returned to normal.

Step 11. Partially open the Accelerator Control Valve just enough to allow air to slowly pass through the Accelerator Control Valve.

Using a watch, note the time for the pressure in the Differential Chamber of the Accelerator to increase to 10 psi. The time should be within the range of values indicated in Table A for optimum performance of the Accelerator.

NOTE

If the time to pressurize the Differential Chamber to 10 psi is not within the range of values given in the Table A, then the Accelerator control Valve should be closed and the corrective procedure described in the Care and Maintenance Section followed.

Step 12. When the air pressure in the

Differential Chamber of the Accelerator is equal to that in the system, then the Accelerator is set and ready for service.

Step 13. Close the Accelerator Control Valve and then slowly open the dry pipe valve's low body drain valve, to bleed off any excess water above the priming level. Reclose the low body drain valve, return system pressure to its normal value, and then completely open the Accelerator Control Valve.

Step 14. Partially open the main control valve. Close the main drain valve as soon as water discharges from the drain connection, and then completely open the main control valve. The fire protection system is now ready for service.

NOTE

After placing a fire protection system in service, notify the proper authorities and advise those responsible for monitoring proprietary and/or central station alarms.

Care and Maintenance

The following procedures and inspections should be performed as indicated, in addition to any specific requirements of the NFPA, and any impairment must be immediately corrected.

The owner is responsible for the inspection, testing, and maintenance of their fire protection system and devices in compliance with this document, as well as with the applicable standards of the National Fire Protection Association (e.g., NFPA 25), in addition to the standards of any authority having jurisdiction. The installing contractor or product manufacturer should be contacted relative to any questions.

It is recommended that automatic sprinkler systems be inspected, tested, and maintained by a qualified Inspection Service.

The Model ACC-1 Accelerator must be maintained and serviced in accordance with the following instructions:

NOTE

If an Accelerator is to be temporarily taken out of service, then the proper authorities and all personnel who may be affected must be notified.

Before performing an alarm test, notify the proper authorities and all personnel who may be affected.

Before closing a fire protection system main control valve for inspection or

maintenance work on the fire protection system that it controls, permission to shut down the affected fire protection system must be obtained from the proper authorities and all personnel who may be affected by this action must be notified.

Accelerator Inspection Procedure

It is recommended that the following Accelerator inspection procedure be performed at quarterly.

Step 1. Verify that the Reset Knob is screwed in.

Step 2. Close the system's main control valve and open the main drain valve to relieve the supply pressure to the dry pipe valve.

Step 3. Verify that the Accelerator Control Valve is open.

Step 4. Open the Inspector's Test Connection. Verify that the time to Accelerator trip is essentially the same as in previous tests. A momentary burst of air from the Automatic Drain Valve indicates that the Accelerator has tripped.

NOTE

As the system pressure is decreasing, check for any sign of water being discharged from the Accelerator Relief Port.

Step 5. Depress the plunger of the Automatic Drain Valve. A steady stream of exhausting air indicates that the Accelerator has properly latched in the Tripped position.

Step 6. Close the Accelerator Control Valve and the Inspector's Test Connection.

Step 7. Clean out the Strainer at the Accelerator inlet.

NOTE

A clogged strainer can prevent the Accelerator from properly tripping the dry pipe valve.

Step 8. Reset the Accelerator in accordance with Steps 7 through 14 of the Setting Procedure Section.

System Inspection Procedure

It is recommended that the following Accelerator and dry pipe valve inspection procedure be performed at least annually, preferably in the spring or summer of the year. This procedure can only be used whenever there is no danger that flooding the system will expose the water to freezing conditions.

Step 1. Verify that the Reset Knob is screwed in.

Step 2. Open the Inspector's Test Connection. Verify that tripping of the Accelerator operates the dry pipe valve and that water is delivered out of the Inspector's Test connection within the elapsed time required by the authority having jurisdiction.

NOTE

As the system pressure is decreasing, check for any sign of water being discharged from the Accelerator Relief Port.

Step 3. Reset the accelerator and dry pipe valve in accordance with the Setting Procedure Section.

Trouble Shooting

Refer to the following subsections, as applicable. If the designated instructions do not remedy the particular problem, refer to the Accelerator Disassembly and Reassembly subsection.

Water Discharge From Accelerator Relief Port

Use the following instructions if water is discharged from the Accelerator Relief Port during a trip.

Step 1. Verify that the connection from the Accelerator to the system piping is installed in accordance with Step 4 of the Installation Section. Correct if necessary.

Step 2. Investigate for and correct any condition which could result in an excessive build-up of drain back and/or condensate water.

Step 3. Review procedures which were used to set the Accelerator. Failure to perform Step 5 of the Setting Procedure can permit a small amount of water to enter the Pilot Chamber of the Accelerator.

Slow Fill of Differential Chamber

Use the following instructions if the time to fill the Differential Chamber is longer than the maximum value indicated in Step 11 of the Setting Procedure Section.

Step 1. Check to see that the Accelerator was reset per Step 8 of the Setting Procedure Section.

Step 2. Close the system's main control valve and open the main drain valve.

Step 3. Check for any sign of external leakage past the Accelerator Pressure Gauge, Vent, and Restriction Access Plug connections.

Step 4. Check for any sign of external leakage past the Reset Knob and Cover Gasket.

Step 5. Close the Accelerator Control Valve.

Step 6. Gently insert a 3/32 inch or smaller diameter probe into the Relief Port. If the probe can be inserted more than 1/4 inch then the Lever has not reset and the Accelerator must be disassembled for internal inspection. See the instructions for Accelerator Disassembly and Reassembly.

Step 7. Slowly remove the Accelerator Vent Plug to bleed all pressure from the Differential Chamber and then slowly remove the Restriction Access Plug to bleed all pressure from the Pilot Chamber.

Step 8. Replace the Restriction and then the Restriction Access Plug.

Step 9. Place the fire protection system back in service in accordance with Steps 9 through 14 of the Setting Procedure Section.

Unexplained Accelerator Trip

Use the following instructions if there is an unexplained accidental trip of the Accelerator.

Step 1. Verify that the connection from the Accelerator to the system piping is installed in accordance with Step 4 of the Installation Section. Correct if necessary.

Step 2. Verify the time to fill the Differential Chamber as described in Step 11 of the Setting Procedure Section. If the time to fill the Differential Chamber to 10 psi is longer than the maximum indicated value, then follow the instructions given under "Slow Fill of Differential Chamber".

Step 3. If the time to fill the Differential Chamber is within the indicated range of values, then investigate for and correct any condition which could result in excessive leakage of system air pressure.

Fast Fill of Differential Chamber or Long Time to Accelerator Trip

Use the following instructions if the time to fill the Differential Chamber is shorter than the minimum value indicated in Step 11 of the Setting Procedure Section. This procedure should also be followed if the time to Accelerator trip (following opening of the

Inspector's Test Connection) is significantly longer than expected.

Step 1. Close the system's main control valve and open the main drain valve.

Step 2. Close the Accelerator Control Valve.

Step 3. Slowly remove the Accelerator Vent Plug to bleed all pressure from the Differential Chamber and then slowly remove the Restriction Access Plug to bleed all pressure from the Pilot Chamber.

Step 4. Using a slotted screw driver, check the tightness of the Restriction.

Step 5. Inspect the Restriction's O-ring seal. The O-ring must be replaced if there are any signs of nicks, cuts, or deterioration due to age. Replace the Restriction after cleaning and lubricating its O-ring with a non-petroleum based grease (such as Dow Corning FS3452). Replace the Vent Plug and Restriction Access Plug.

Step 6. If the Restriction and its O-ring are found to be in good condition, then it is likely that there is leakage past the Plunger. Remove the Cover from the Base. Check that the six screws securing the Upper Diaphragm Plate to the Cover are tight.

Inspect the Upper Diaphragm for any sign of cracks, pin holes or deterioration due to age. Replace the Plunger if there is any possibility of leakage past the Upper Diaphragm.

Step 7. Reassemble the Accelerator and place the fire protection system back in service in accordance with Steps 10 through 14 of the Setting Procedure Section.

Air Leakage Out Automatic Drain

If there is leakage of air out the Automatic Drain of the dry pipe valve, after the Accelerator and dry pipe valve have been placed in service, then it will be necessary to first determine whether the leakage is past the Accelerator or the dry pipe valve.

Close the Accelerator Control Valve. Slowly remove the Accelerator Vent Plug to bleed all pressure from the Differential Chamber and then slowly remove the Restriction Access Plug to bleed all pressure from the Pilot Chamber.

If leakage out the Automatic Drain persists then refer to the dry pipe valve Technical Data Sheet for maintenance instructions. If leakage out of the Automatic Drain stops, then the Accelerator will have to be taken out of service and the Accelerator Plug Seat re-

moved for cleaning of the seat and the lower O-ring area on the Exhaust Valve.

Accelerator Disassembly and Reassembly (For Internal Inspection As Necessary)

Step 1. Close the system's main control valve and open the main drain valve.

Step 2. Close the Accelerator Control Valve.

Step 3. Slowly remove the Accelerator Vent Plug to bleed all pressure from the Differential Chamber and then slowly remove the Restriction Access Plug to bleed all pressure from the Pilot Chamber.

Step 4. Break the union connections at the Inlet and Outlet of the Accelerator and remove it from the line. Plug the connection to the intermediate chamber of the dry pipe valve and place the fire protection system in service while the Accelerator is out for maintenance.

Step 5. Remove the eight screws holding the Cover to the Base and remove the Cover.

Step 6. Remove the six screws holding the Upper Diaphragm Plate to the Cover. Remove the Plunger and inspect the Upper Diaphragm to be sure that it is flexible and free from physical damage or deterioration due to age.

Check the Jam Nut to assure that it is assembled tightly to its Screw. Re-mount the Plunger and Upper Diaphragm Plate taking care to cross-tighten the screws uniformly.

Step 7. Replace the Restriction if it has been wetted. Clean and lubricate the Restriction O-ring seal with a non-petroleum based grease (such as Dow Corning FS3452).

Replace the Vent Plug and Restriction Access Plug.

Step 8. Remove the Retaining Ring from the Upper Plug portion of the Exhaust Valve. Remove the four screws holding the Pivot Plate. Remove the sub-assembly of the Lever and Pivot Plate, the Exhaust Valve, the Anti-Flood Valve and the Relief Valve.

Step 9. Inspect the Lower Diaphragm to be sure that it is flexible and free from physical damage or deterioration due to age.

Step 10. Check to see that the Exhaust Valve components are securely assembled together. Only tighten by gripping the flats using an open end type wrench.

Step 11. Inspect the O-ring on the Lower Plug. It must be replaced if there are any signs of nicks, cuts or deterioration.

Step 12. Inspect the Relief and Anti-Flood Valves. If either is bent or nicked it must be replaced.

Step 13. Remove and inspect the Latch. The catch leaf should extend 5/16 to 3/8 inches in the free state.

Step 14. Remove the Relief Valve Seat. Remove the O-ring and Seal Washer. Carefully clean the O-ring and Seal Washer seating surfaces in the valve seat and Accelerator Base. If the O-ring or Seal Washer is nicked, cut, or shows signs of deterioration, it must be replaced.

Step 15. Replace the Seal Washer in the Accelerator Base. Apply a thin film of Dow Corning FS3452 Fluorosilicone Grease to the valve seat. Place the O-ring in its seat (the lubricant will hold it in place) and then thread the Relief Valve Seat into the Body with 10 to 15 ft.lbs. of torque.

Step 16. Remove the Anti-Flood Seat Assembly w/Ball Float. Check for damaged parts and for freedom of Ball movement. If parts are damaged or inoperative, the Assembly must be replaced.

Step 17. After checking the Anti-Flood Seat Assembly w/Ball Float, lubricate the O-ring with a thin film of Dow Corning FS3452 Fluorosilicone Grease, and thread the Assembly into the Body with 10 to 15 ft.lbs. of torque.

Step 18. Remove the Reset Knob. Carefully clean the O-ring and its seating surface. If the O-ring is cut, nicked, or shows signs of deterioration it must be replaced. Lubricate the O-ring with a thin film of Dow Corning FS3452 Fluorosilicone Grease.

Step 19. Reassemble the Accelerator in the following order.

- a. Thread the Reset Knob into the Base finger tight.
- b. Set the Anti-Flood Valve (with Retaining Ring in place) and the Compression Spring into their seat.
- c. Set the Exhaust Valve in place.
- d. Slide the Relief Valve into the slot at the end of the Lever and then remount the sub-assembly of the Lever and Pivot Plate in the Base, taking care to cross-tighten the screws uniformly.
- e. Replace the Retaining Ring on the Upper Plug.
- f. Push the Anti-Flood Valve end of the Lever down and release it

twice to assure that there is no binding.

- g. Replace the Latch making sure that the notch in the bottom straddles the Reset Knob and that the tabs at the top are seated in the Base. Place the Lever in the Tripped (latched) position.
- h. Place the Cover upside down. Set the Cover Gasket in place and then push all eight screws through the Gasket to assist in assembling the Cover to the Base.
- i. Align the Cover with the Base and tighten all of the screws uniformly.
- j. Replace the Vent Plug and the Restriction Access Plug.
- k. Reinstall the Accelerator and return the system to service in accordance with the Setting Procedure Section.

Limited Warranty

Products manufactured by Tyco Fire & Building Products (TFBP) are warranted solely to the original Buyer for ten (10) years against defects in material and workmanship when paid for and properly installed and maintained under normal use and service. This warranty will expire ten (10) years from date of shipment by TFBP. No warranty is given for products or components manufactured by companies not affiliated by ownership with TFBP or for products and components which have been subject to misuse, improper installation, corrosion, or which have not been installed, maintained, modified or repaired in accordance with applicable Standards of the National Fire Protection Association, and/or the standards of any other Authorities Having Jurisdiction. Materials found by TFBP to be defective shall be either repaired or replaced, at TFBP's sole option. TFBP neither assumes, nor authorizes any person to assume for it, any other obligation in connection with the sale of products or parts of products. TFBP shall not be responsible for sprinkler system design errors or inaccurate or incomplete information supplied by Buyer or Buyer's representatives.

In no event shall TFBP be liable, in contract, tort, strict liability or under any other legal theory, for incidental, indirect, special or consequential damages, including but not limited to labor charges, regardless of whether

TFBP was informed about the possibility of such damages, and in no event shall TFBP's liability exceed an amount equal to the sales price.

The foregoing warranty is made in lieu of any and all other warranties, express or implied, including warranties of merchantability and fitness for a particular purpose.

This limited warranty sets forth the exclusive remedy for claims based on failure of or defect in products, materials or components, whether the claim is made in contract, tort, strict liability or any other legal theory.

This warranty will apply to the full extent permitted by law. The invalidity, in whole or part, of any portion of this warranty will not affect the remainder.

Ordering Information

Orders for the ACC-1 Accelerator, trim and replacement parts must include the description and Part Number (P/N). The Complete Model ACC-1 Accelerator Package includes the Accelerator and Basic Galvanized Trim.

Complete Package:

Specify: Complete Model ACC-1 Accelerator Package, P/N 52-311-2-002.

Accelerator Only:

Specify: Model ACC-1 Accelerator, P/N 52-311-1-001.

Basic Galvanized Trim Only:

Specify: Model ACC-1 Accelerator, Basic Galvanized Trim for 2-1/2 thru 6 inch Model DPV-1 Dry Pipe Valves, P/N 52-311-2-010.

Replacement Parts for Accelerator:

(Specify description) for use with Model ACC-1 Accelerator, P/N (see Figure 3).

Replacement Trim Parts:

Specify: (specify description), P/N (see Figure 4).

