

VISCOUS TEE TYPE HOLDER SERIES

DESCRIPTION

The Fike Viscous Tee Rupture Disc Holder is designed primarily for the overpressure protection of systems that process medias of high viscosity or that have the tendency to coat or plug system piping. The Viscous Tee design causes the process media to sweep across the surface of the rupture disc, minimizing product build-up and plugging that could affect disc performance. (See Figure 1).

The Viscous Tee Assembly consists of a special weir-type body, a teflon gasket, a holder inlet (base), a holder outlet (holddown) with capscrews for pre-assembly, and studs and nuts (for outlet companion flange). Reference Figure 2 for component identification. The rupture disc is a separate item and is show for reference only. The outlet companion flange is optional, and in some cases requires special bolting configurations.

Viscous Tee sizes are 2, 3, 4 and 6 inch 150 ANSI rated pipe sizes. Other sizes and ratings are available on an engineered basis. Reference Table 1 for dimensions of standard assemblies. Standard materials are carbon steel and 316 SST. Teflon lining can be provided upon request. Alloy studs and nuts are provided for the outlet companion flange.

The Viscous Tee Rupture Disc Holder is designed to accommodate forward acting 30° seat discs (Prebulged [P] Series and HO/HOV Series) and flat seat discs (Poly-SD and SCRD series). Multiple design configurations are available to accommodate specific process conditions. Please consult factory for more information.

ORDERING INFORMATION

When ordering Viscous Tee Holders, specify size (nominal pipe size of installation), ANSI rating, type of rupture disc to be used, rupture disc outlet companion flange requirements and material requirements.



Viscous Tee Holder

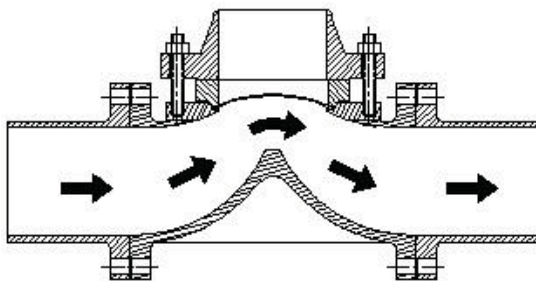

Figure 1

Form No. R.1.10.01-1

TABLE 1
 DIMENSIONS (150 ANSI VISCOUS TEE ASSEMBLIES*)

NOMINAL SIZE	A	B (APPROX.)	C
2" (DN 50)	7.50 (190.5)	3.13 (79.4)	.75 (19.1)
3" (DN 80)	10 (254)	3.88 (98.6)	.94 (24)
4" (DN 100)	12.50 (317.5)	4.25 (108)	.94 (24)
6" (DN 150)	16 (406.4)	5.75 (146.1)	1.00 (25.4)

* Reference FIGURE 2 for dimension call-outs.

1. Companion flange bolt pattern is not 150 ANSI Standard on 2" and 6" sizes.
2. Dimension B, Fig. 2, depends on companion flange configuration.

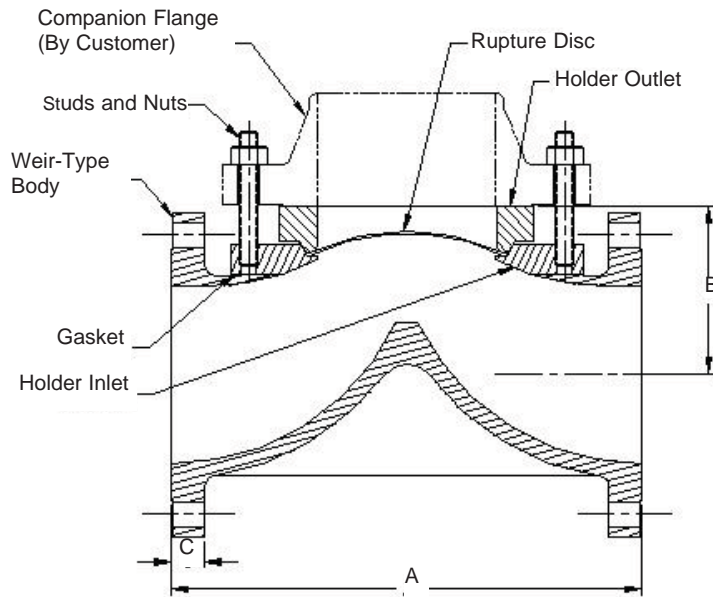

Figure 2

