

PNEUMATIC RACK AND PINION ACTUATORS

HAM-LET PNEUMATIC ACTUATORS

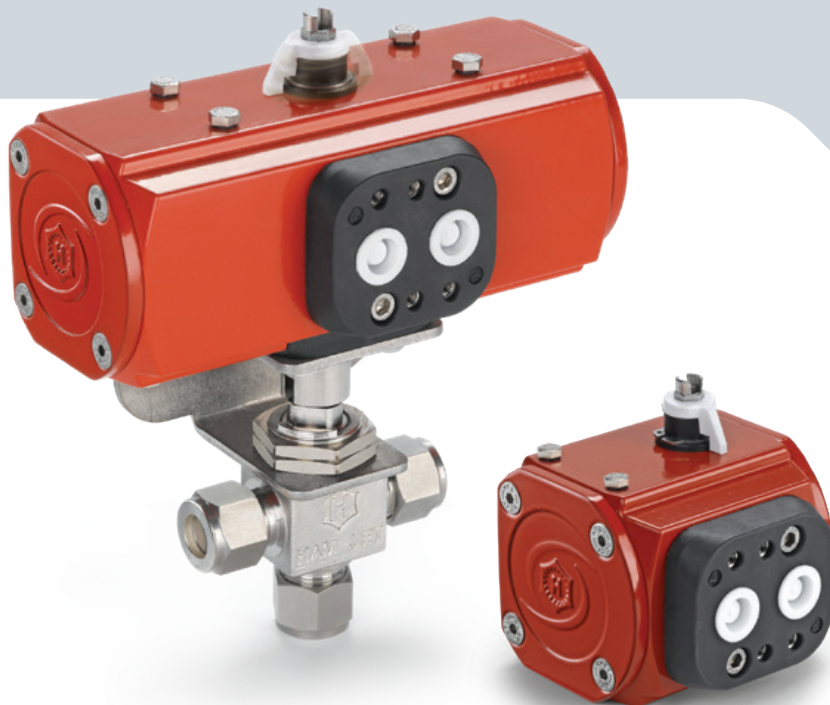

ADVANCED TORQUE TO SIZE RATIO



FEATURES:

- Pneumatic Rack and Pinion Actuators
- 90° Actuation for 2-way valves (Straight & Angle)
- 180° Actuation for 3-way (T-type) valves
- Actuators comply with industry standards for interface with ISO 5211, NAMUR and VDI/VDE 3845
- Actuated valves are available factory assembled or separately, actuator and mounting kits
- Aluminum actuators are available as standard, Stainless Steel and Electric actuators are available upon request
- Limit switches, proximity sensors, position indicators, pilot valves and other accessories are available upon request
- Standard Temperature range: -32°C to 90°C (-25.6°F to 194°F)
Optional: High Temperature: -30°C to 120°C (-22°F to 248°F)
Low Temperature: -50°C to 80°C (-58°F to 176°F)

GENERAL

- Four standard actuator sizes are available upon request: Mini (designator "A1"), Small (designator "A2") and 180° actuator (designator "A2T"), Medium (designator "A3"), and Large (designator "A4").
- Improved operational speed enables better valve opening and closing control.
- ATEX certification of Valves-Actuators assemblies is available on request at the time of order quotation.



MATERIAL OF CONSTRUCTION

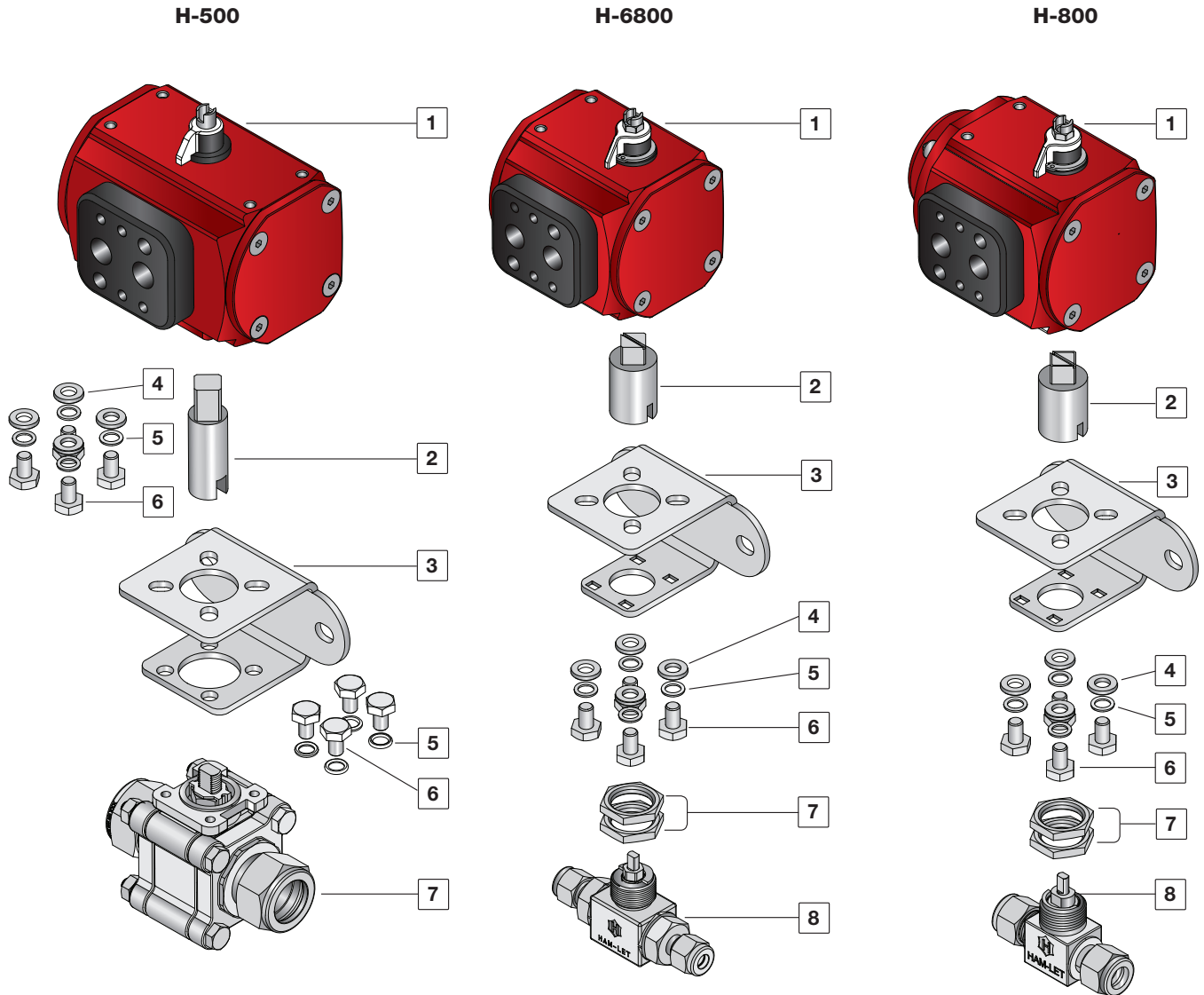

No.	H-500 SERIES			H-6800 SERIES			H-800 SERIES		
	Part	Qty.	Material	Part	Qty.	Material	Part	Qty.	Material
1	Actuator	1	Al 356-T5	Actuator	1	Al 356-T5	Actuator	1	Al 356-T5
2	Coupling	1	St.St.316	Coupling	1	St.St.316	Coupling	1	St.St.316
3	Bracket	1	St.St.304	Bracket	1	St.St.304	Bracket	1	St.St.304
4	Washer flat	4	St.St.304	Washer flat	4	St.St.304	Washer flat	4	St.St.304
5	Washer spring	8	St.St.304	Washer spring	4	St.St.304	Washer spring	4	St.St.304
6	Screw	8	St.St.304	Screw	4	St.St.304	Screw	4	St.St.304
7	H-500	1	St.St.316	Panel nut	2	St.St.316	Panel nut	2	St.St.316
8	-	-	-	H-6800	1	St.St.316	H-800	1	St.St.316

H-6800 SERIES

H-6800 High Performance Ball Valves features, materials of construction, and technical data are available in the H-6800 valves section.

The selection of Valve-Actuator assemblies provided herein is based on:

- Valve maximum allowable working pressure
- Ambient temperature (50 to 100°F /10 to 37°C)
- Actuator fits to valve based on operating pressure of 6 bar, as per table A.

To order H-6800 ball valve factory assembled with an actuator, add the actuator designator to the valve part number/description per the below table.

Example:

H6800SSL1/4PSS with standard Double Acting Aluminum Actuator
H6800SSL1/4PS-A1

To order an actuator and mounting kit for field assembly:

Double acting Actuator ordering number: Z-A1

Corresponding mounting kit: Z-6800-MK-1/4-F03-F04-A1

Lubricant free Valves:

For Spring Return Actuator - select one size bigger than offered in the table below.

Example: If the offered actuator in the table is A2C, select A3C

For Double Acting Actuator - please contact your local representative

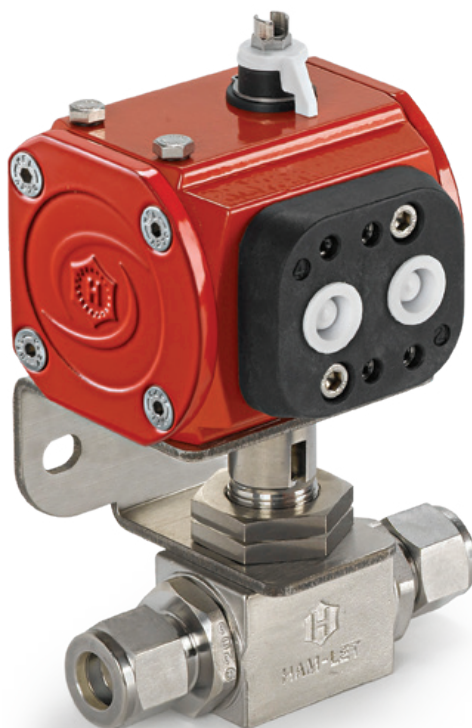
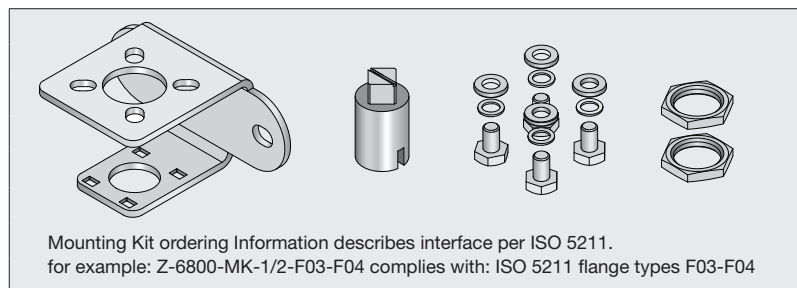

TABLE 1

Series	Ends Size	Seats	Minimum Actuator Operating Pressure Bar (Psi)	Actuator Designators (Factory assembled)			Actuator Ordering Code		Mounting Kit Ordering Info
				Spring Return		Double Acting	Spring Return	Double Acting	
				NO	NC				
H-6800	1/16"-3/8" (3mm-10mm)	Modified PTFE PCTFE	5 (72.5)	A1O	A1C	A1	Z-A1S	Z-A1	Z-6800-MK-1/4"-F03-F04-A1
		PEEK	5 (72.5)	A2O	A2C		Z-A2S	Z-6800-MK-1/4"-F03-F04-A2	
	1/2"-3/4" (12mm-18mm)	Modified PTFE	5 (72.5)	A1O	A1C	A1	Z-A1S	Z-A1	Z-6800-MK-1/2"-F03-F04-A1
		PCTFE	5 (72.5)	A2O	A2C		Z-A2S	Z-6800-MK-1/2"-F03-F04-A2	
		PEEK	5 (72.5)	A3O	A3C	Z-A3S	Z-A2	Z-6800-MK-1/2"-F03-F04-A3	
	H-6800 T-type	1/16"-3/8" (3mm-10mm)	Modified PTFE PCTFE PEEK	5 (72.5)	A2TS	A2TS	A2T	Z-A2TS	Z-A2T
1/2"-3/4" (12mm-18mm)		Z-6800-MK-1/2"-F03-F04-A2							

Ham-Let ISO 5211 mounting kits for H-6800 Series contain:



Mounting Kit ordering Information describes interface per ISO 5211.
for example: Z-6800-MK-1/2-F03-F04 complies with: ISO 5211 flange types F03-F04

Part	Qty	Material
Coupling	1	St.St 316
Bracket	1	St.St 304
Screw	4	St.St 304
Washer spring	4	St.St 304
Washer flat	4	St.St 304
Panel nut	2	St.St 316
Mounting instructions	1	-

H-800 SERIES

H-800 One Piece Ball Valves features, materials of construction, and technical data, are available in the H-800 valves section.

The selection of Valve-Actuator assemblies provided herein is based on:

- Valve maximum allowable working pressure
- Ambient temperature (50 to 100°F / 10 to 37°C)
- Actuator fits to valve based on operating pressure of 6 bar, as per table A.

To order H-800 ball valve factory assembled with an actuator, the actuator designator shall be added to the valve part number / description per the below table.

Example:

H-800S-SS-L-1/4 with standard Spring Return Aluminum Actuator Normally Closed

H-800S-SS-L-1/4-A1C

To order an actuator and mounting bracket kit for field assembly: Spring Return Actuator ordering number: **Z-A1S** Corresponding mounting bracket kit:

Z-800S-MK-F03-F04-A1

Lubricant free Valves:

For spring return actuator - select one size bigger then offered in the table below.

Example: If the offered actuator in the table is A2C, select A3C

For double acting actuator - Please contact your local representative

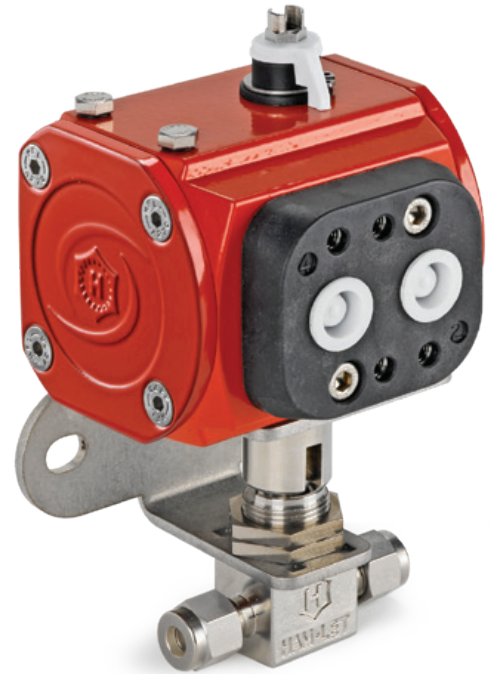

TABLE 2

Series	Ends Size	Seats	Minimum Actuator Operating Pressure Bar (Psi)	Actuator Designators (Factory Assembled)			Actuator Ordering Code		Mounting Kit Ordering info
				Spring Return		Double Acting	Spring Return	Double Acting	
				NO	NC				
H-800	S	PFA	5 (72.5)	A1O	A1C	A1	Z-A1S	Z-A1	Z-800S-MK-F03-F04-A1
	M			A1O	A1C		Z-A1S		Z-800M-MK-F03-F04-A1
	L			A2O	A2C		Z-A2S		SR: Z-800L-MK-F03-F04-A2 DA: Z-800L-MK-F03-F04-A1
H-800 T-Type	S	PFA	5 (72.5)	A2TS	A2TS	A2T	Z-A2TS	Z-A2T	Z-800S-MK-F03-F04-A2
	M								Z-800M-MK-F03-F04-A2
	L								Z-800L-MK-F03-F04-A2

Ham-Let ISO 5211 mounting kits for H-800 Series contain:

Part	Qty	Material
Coupling	1	St.St 316
Bracket	1	St.St 304
Screw	4	St.St 304
Washer spring	4	St.St 304
Washer flat	4	St.St 304
Panel nut	2	St.St 316
Mounting instructions	1	-

Mounting Kit ordering Information describes interface per ISO 5211.
for example: Z-800M-MK-F03-F04-A2 complies with: ISO 5211 flange types F03-F04

H-500 SERIES

H-500 Three Piece Ball Valves features, materials of construction, and technical data, are available in the H-500 valves section.

The selection of Valve-Actuator assemblies provided herein is based on:

- Valve maximum allowable working pressure
- Ambient temperature (50 to 100°F / 10 to 37°C)
- Actuator fits to valve based on operating pressure of 6 bar, in accordance with table A.

To order H-500 ball valve factory assembled with an actuator, the actuator designator shall be added to the valve part number/description per the below table.

Example:

H-500-SS-L-3/4-T with standard Double Acting Aluminum Actuator

H-500-SS-L-3/4-T-A2

To order an actuator and mounting kit for field assembly: Double Acting Actuator ordering number: **Z-A2** Corresponding mounting kit: **Z-500-MK-3/4 -F03-F04-A2**

Lubricant free Valves:

For Spring Return Actuator - select one size bigger than offered in the table below.

Example: If the offered actuator in the table is A2C, select A3C

For Double Acting Actuator - please contact your local representative



TABLE 3

Series	Ends Size	Seats	Minimum Actuator Operating Pressure Bar (Psi)	Actuator Designators (Factory Assembled)		Actuator Ordering Code		Mounting Kit Ordering Info	
				Spring Return		Double Acting	Spring Return		Double Acting
				NO	NC				
H-500S	1/4", 3/8" (6 mm, 10 mm)	Modified PTFE	5 (72.5)	A1O	A1C	A1	Z-A1S	Z-A1	Z-500S-MK-1/4"-F03-F04-A1
H-500	1/4"-1/2" (6 mm-12 mm)	PTFE Modified PTFE	5 (72.5)	A2O	A2C	A1	Z-A2S	Z-A1	SR: Z-500-MK-1/2"-F03-F04-A2 DA: Z-500-MK-1/2"-F03-F04-A1
		St.St. PTFE	5 (72.5)	A2O	A2C	A2	Z-A2S	Z-A2	Z-500-MK-1/2"-F03-F04-A2
		PEEK	5 (72.5)	A4O	A4C	A3	Z-A4S	Z-A3	SR: Z-500-MK-1/2"-F05-F07-A4 DA: Z-500-MK-1/2"-F04-F05-A3
	3/4" (20 mm)	PTFE Modified PTFE	5 (72.5)	A2O	A2C	A2	Z-A2S	Z-A2	Z-500-MK-3/4"-F03-F04-A2
		St.St. PTFE	5 (72.5)	A3O	A3C	A2	Z-A3S	Z-A2	SR: Z-500-MK-3/4"-F04-F05-A3 DA: Z-500-MK-3/4"-F03-F04-A2
		PEEK	5 (72.5)	A4O	A4C	A4	Z-A4S	Z-A4	Z-500-MK-3/4"-F05-F07-A4
	1" (25 mm)	PTFE Modified PTFE St.St. PTFE	5 (72.5)	A4O	A4C	A3	Z-A4S	Z-A3	SR: Z-500-MK-1"-F05-F07-A4 DA: Z-500-MK-1"-F04-F05-A3
		PEEK	5 (72.5)	A5O	A5C	A4	Z-A5S	Z-A4	SR: Z-500-MK-1"-F05-F07-A5 DA: Z-500-MK-1"-F05-F07-A4

Ham-Let ISO 5211 mounting kits for H-500 Series contain:

<p>Note: Mounting Kit ordering Information describes interface per ISO 5211. For example: Z-500-MK-3/4-F03-F04 complies with: ISO 5211 flange types F03-F04</p>	Part	Qty	Material
	Coupling	1	St.St 316
	Bracket	1	St.St 304
	Screw	8	St.St 304
	Washer spring	8	St.St 304
	Washer flat	4	St.St 304
	Panel nut	1	St.St 316
	Mounting instructions	1	-

Dimensions for Assembled Actuators - H-800 & H-6800 2-WAY VALVE SERIES

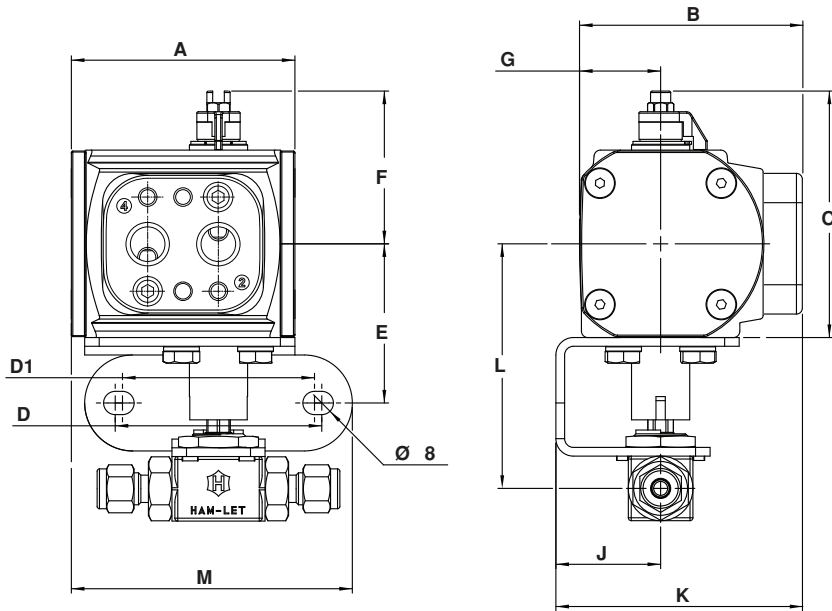

Series	Body Designator	Ends Size	Seats Material	Actuator Model	Units	A	B	C	D	D1	E	F	G	J	K	L	M
H-6800	1/4"	1/16"-3/8" (3mm-10mm)	Modified PTFE PCTFE	SR A1S	mm	96.5	76.1	84.1	71	66	54.7	51.8	27.9	35	83.2	88.5	116.2
				DA A1	inch	3.8	3.0	3.31	2.8	2.6	2.15	2.04	1.1	1.38	3.27	3.48	4.57
				DA A1	mm	76.8	76.1	84.1	71	66	54.7	51.8	27.9	35	83.2	88.5	96.6
			PEEK	SR A2S	mm	140.2	76.1	88.6	71	66	59.2	51.8	27.9	35	83.2	92.8	x
				DA A1	inch	5.52	3.0	3.49	2.8	2.6	2.33	2.04	1.1	1.38	3.27	3.65	x
				DA A1	mm	76.8	76.1	84.1	71	66	54.7	51.8	27.9	35	83.2	88.5	96.6
	1/2"	1/2"-3/4" (12mm-18mm)	Modified PTFE PCTFE	SR A1S	mm	96.5	76.1	84.1	71	66	54.7	51.8	27.9	35	83.2	93.2	116.2
				DA A1	inch	3.8	3.0	3.31	2.8	2.6	2.15	2.04	1.1	1.38	3.27	3.67	4.57
				DA A1	mm	76.8	76.1	84.1	71	66	54.7	51.8	27.9	35	83.2	93.2	96.6
			PCTFE	SR A2S	mm	140.2	76.1	88.6	71	66	59.7	51.8	27.9	35	83.2	97.7	x
				DA A2	inch	5.52	3.0	3.49	2.8	2.6	2.35	2.04	1.1	1.38	3.27	3.85	x
				DA A2	mm	101	76.1	88.6	71	66	59.7	51.8	27.9	35	83.2	97.7	x
PEEK	SR A3S	mm	152.3	84.1	111.3	71	66	65.7	68.1	31.9	44	96.2	104.2	x			
	DA A2	inch	6.0	3.31	4.38	2.8	2.6	2.58	2.68	1.25	1.73	3.79	4.10	x			
	DA A2	mm	101	76.1	88.6	71	66	59.7	51.8	27.9	35	83.2	97.7	x			
H-800	S	1/16"-1/4" (3mm-6mm)	PFA	SR A1S	mm	96.5	76.1	84.1	71	66	54.7	51.8	27.9	35	83.2	85.8	116.2
				DA A1	inch	3.8	3.0	3.31	2.8	2.6	2.15	2.04	1.1	1.38	3.27	3.38	4.57
				DA A1	mm	76.8	76.1	84.1	71	66	54.7	51.8	27.9	35	83.2	85.8	96.6
				DA A1	inch	3.02	3.0	3.31	2.8	2.6	2.15	2.04	1.1	1.38	3.27	3.38	3.8
	M	1/4"-3/8" (6mm-8mm)		SR A1S	mm	96.5	76.1	84.1	71	66	54.7	51.8	27.9	35	83.2	88.4	116.2
				DA A1	inch	3.8	3.0	3.31	2.8	2.6	2.15	2.04	1.1	1.38	3.27	3.48	4.57
				DA A1	mm	76.8	76.1	84.1	71	66	54.7	51.8	27.9	35	83.2	88.4	96.6
				DA A1	inch	3.02	3.0	3.31	2.8	2.6	2.15	2.04	1.1	1.38	3.27	3.48	3.8
	L	3/8"-1/2" (10mm-12mm)	SR A2S	mm	140.2	76.1	88.6	71	66	59.7	51.8	27.9	35	83.2	95.9	x	
			DA A1	inch	5.52	3.0	3.49	2.8	2.6	2.35	2.04	1.1	1.38	3.27	3.77	x	
			DA A1	mm	76.8	76.1	84.1	71	66	54.7	51.8	27.9	35	83.2	91.4	96.6	
			DA A1	inch	3.02	3.0	3.31	2.8	2.6	2.15	2.04	1.1	1.38	3.27	3.6	3.8	

Dimensions for Assembled Actuators- H-500 SERIES

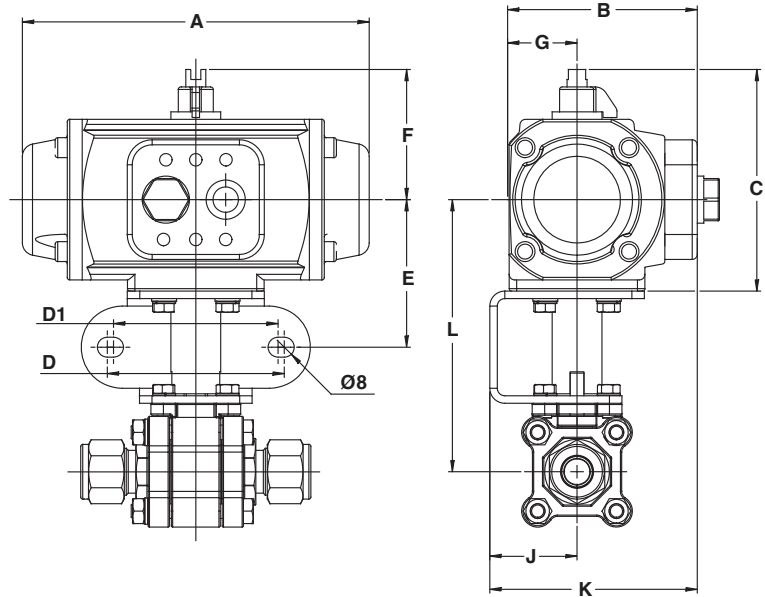

Series	Body Designator	Ends Size	Seats Material	Actuator Model		Units	A	B	C	D	D1	E	F	G	J	K	L
							mm	inch	mm	inch	mm	inch	mm	inch	mm	inch	mm
H-500S	1/4"	1/4", 3/8" (6mm, 10mm)	Modified PTFE	SR	A1S	mm	95.8	76.1	84.1	33.0	29.0	48.2	51.8	27.9	31.0	79.2	88.2
						inch	3.77	3.00	3.31	1.30	1.14	1.90	2.04	1.10	1.22	3.12	3.47
				DA	A1	mm	76.9	76.1	84.1	33.0	29.0	48.2	51.8	27.9	31.0	79.2	88.2
						inch	3.03	3.00	3.31	1.30	1.14	1.90	2.04	1.10	1.22	3.12	3.47
H-500	1/2"	1/4"-1/2" (6mm-12mm)	PTFE Modified PTFE	SR	A2S	mm	140.2	76.1	88.6	71	66	59.7	51.8	27.9	35	83.2	109.2
						inch	5.52	3.0	3.49	2.8	2.6	2.35	2.04	1.1	1.38	3.27	4.3
			DA	A1	mm	76.8	76.1	84.1	71	66	54.7	51.8	27.9	35	83.2	104.7	
					inch	3.02	3.0	3.31	2.8	2.6	2.15	2.04	1.1	1.38	3.27	4.12	
			St.St. PTFE	SR	A2S	mm	140.2	76.1	88.6	71	66	59.7	51.8	27.9	35	83.2	109.2
						inch	5.52	3.0	3.49	2.8	2.6	2.35	2.04	1.1	1.38	3.27	4.3
	DA	A2	mm	101	76.1	88.6	71	66	59.7	51.8	27.9	35	83.2	109.2			
			inch	3.97	3.0	3.49	2.8	2.6	2.35	2.04	1.1	1.38	3.27	4.3			
	PEEK	SR	A4S	mm	200.8	109.4	128.5	71.0	66.0	71.7	79.2	47.7	44.0	105.7	121.7		
				inch	7.91	4.31	5.06	2.80	2.60	2.82	3.12	1.88	1.73	4.16	4.79		
	DA	A3	mm	152.3	84.1	111.3	71	66	65.7	68.1	31.9	44	96.2	115.7			
			inch	6.0	3.31	4.38	2.8	2.6	2.58	2.68	1.25	1.73	3.79	4.55			
	3/4"	3/4" (18mm)	PTFE Modified PTFE	SR	A2S	mm	140.2	76.1	88.6	71	66	59.7	51.8	27.9	35	83.2	112.5
						inch	5.52	3.0	3.49	2.8	2.6	2.35	2.04	1.1	1.38	3.27	4.43
			DA	A2	mm	101	76.1	88.6	71	66	59.7	51.8	27.9	35	83.2	112.5	
					inch	3.97	3.0	3.49	2.8	2.6	2.35	2.04	1.1	1.38	3.27	4.43	
			St.St. PTFE	SR	A3S	mm	152.3	84.1	111.3	71	66	65.7	68.1	31.9	44	96.2	119
						inch	6.0	3.31	4.38	2.8	2.6	2.58	2.68	1.25	1.73	3.79	4.68
DA	A2	mm	101	76.1	88.6	71	66	59.7	51.8	27.9	35	83.2	112.5				
		inch	3.97	3.0	3.49	2.8	2.6	2.35	2.04	1.1	1.38	3.27	4.43				
PEEK	SR	A4S	mm	200.8	109.4	128.5	71.0	66.0	71.7	79.2	47.7	44.0	105.7	125.0			
			inch	7.91	4.31	5.06	2.80	2.60	2.82	3.12	1.88	1.73	4.16	4.92			
DA	A4	mm	200.8	109.4	128.5	71.0	66.0	71.7	79.2	47.7	44.0	105.7	125.0				
		inch	7.91	4.31	5.06	2.80	2.60	2.82	3.12	1.88	1.73	4.16	4.92				

Dimensions for Assembled Actuators- H500- SERIES

(Cont'd)

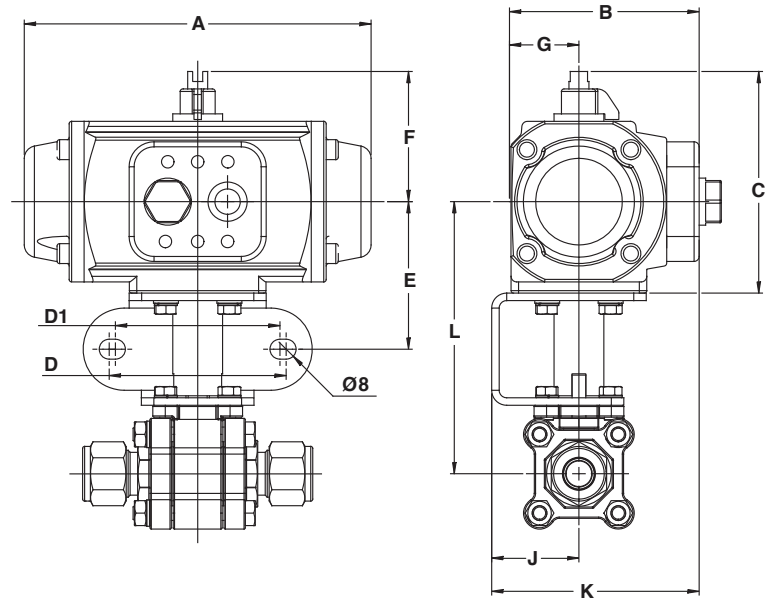

Series	Body Designator	Ends Size	Seats Material	Actuator Model		Units	A	B	C	D	D1	E	F	G	J	K	L
H-500	1"	1" (25 mm)	St.St. PTFE PTFE Modified PTFE	SR	A4S	mm	200.8	109.4	128.5	71.0	66.0	71.7	79.2	47.7	44.0	105.7	131.7
					inch	7.91	4.31	5.06	2.80	2.60	2.82	3.12	1.88	1.73	4.16	5.19	
				DA	A3	mm	152.3	84.1	111.3	71	66	65.7	68.1	31.9	44	96.2	125.7
					inch	6.0	3.31	4.38	2.8	2.6	2.58	2.68	1.25	1.73	3.79	4.95	
			PEEK	SR	A4S	mm	200.8	109.4	128.5	71.0	66.0	71.7	79.2	47.7	44.0	105.7	131.7
					inch	7.91	4.31	5.06	2.80	2.60	2.82	3.12	1.88	1.73	4.16	5.19	
				DA	A4	mm	200.8	109.4	128.5	71.0	66.0	71.7	79.2	47.7	44.0	105.7	131.7
						inch	7.91	4.31	5.06	2.80	2.60	2.82	3.12	1.88	1.73	4.16	5.19

Dimensions for Assembled 180° Actuators - H-800 T-TYPE & H-6800 T-TYPE SERIES

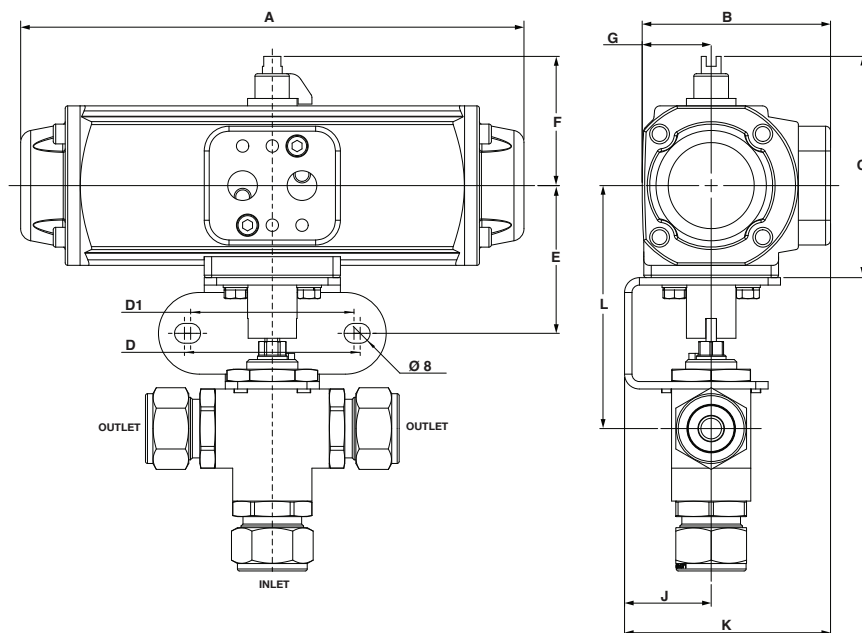

Series	Body Designator	Ends Size	Seats Material	Actuator Model	Units	A	B	C	D	D1	E	F	G	J	K	L	
H-6800 T-type	1/4"	1/16"-3/8" (3mm-10mm)	Modified PTFE PCTFE PEEK	SR	A2ST	mm	204.4	76.1	88.6	71	66	59.7	51.8	27.9	35	83.2	93.0
						inch	8.05	3.0	3.49	2.8	2.6	2.35	2.04	1.1	1.38	3.27	3.66
				DA	A2T	mm	165.4	76.1	88.6	71	66	59.7	51.8	27.9	35	83.2	93.0
						inch	6.51	3.0	3.49	2.8	2.6	2.35	2.04	1.1	1.38	3.27	3.66
	1/2"	1/2"-3/4" (12mm-18mm)	Modified PTFE	SR	A2ST	mm	204.4	76.1	88.6	71	66	59.7	51.8	27.9	35	83.2	97.7
						inch	8.05	3.0	3.49	2.8	2.6	2.35	2.04	1.1	1.38	3.27	3.85
				DA	A2T	mm	165.4	76.1	88.6	71	66	59.7	51.8	27.9	35	83.2	97.7
						inch	6.51	3.0	3.49	2.8	2.6	2.35	2.04	1.1	1.38	3.27	3.85
H-800 T-type	S	1/16"-1/4" (3mm-6mm)	PFA	SR	A2ST	mm	204.4	76.1	88.6	71	66	59.7	51.8	27.9	35	83.2	90.3
						inch	8.05	3.0	3.49	2.8	2.6	2.35	2.04	1.1	1.38	3.27	3.55
				DA	A2T	mm	165.4	76.1	88.6	71	66	59.7	51.8	27.9	35	83.2	90.3
						inch	6.51	3.0	3.49	2.8	2.6	2.35	2.04	1.1	1.38	3.27	3.55
	M	1/4"-3/8" (6mm-8mm)		SR	A2ST	mm	204.4	76.1	88.6	71	66	59.7	51.8	27.9	35	83.2	92.9
						inch	8.05	3.0	3.49	2.8	2.6	2.35	2.04	1.1	1.38	3.27	3.66
				DA	A2T	mm	165.4	76.1	88.6	71	66	59.7	51.8	27.9	35	83.2	92.9
						inch	6.51	3.0	3.49	2.8	2.6	2.35	2.04	1.1	1.38	3.27	3.66
	L	3/8"-1/2" (10mm-12mm)	SR	A2ST	mm	204.4	76.1	88.6	71	66	59.7	51.8	27.9	35	83.2	95.9	
					inch	8.05	3.0	3.49	2.8	2.6	2.35	2.04	1.1	1.38	3.27	3.77	
			DA	A2T	mm	165.4	76.1	88.6	71	66	59.7	51.8	27.9	35	83.2	95.9	
					inch	6.51	3.0	3.49	2.8	2.6	2.35	2.04	1.1	1.38	3.27	3.77	

ALUMINUM PNEUMATIC ACTUATOR - TECHNICAL DATA

A1S: SPRING RETURN

A1: DOUBLE ACTING

DISASSEMBLY

No.	Description	Qty	Material
1	Cap allen screw	8	AISI-304 stainless steel
2	Double acting cap	2	Aluminum alloy (2)+(5)
3	Cap O-ring	2	N.B.R
4	Piston	1	Polyarilamide
5	Cylinder	1	Aluminum alloy (2)+(1)
6	Washer	1	Polyamide 6
7	Spring clip	1	Stainless steel
8	Position indicator	1	Polyacetal
9	Plate O-ring	2	N.B.R.
10	Guide ring	1	Polyacetal + mb
11	Piston O-ring	1	N.B.R.
12	Shaft O-ring	1	N.B.R.
13	Shaft O-ring	1	N.B.R.
14	Preloaded springs	6	DIN-17223-c (3) (4)
15	Spring return cap	1	Aluminum alloy (2) + (5)
16	Shaft	1	Polyamide + S.S.Insert
17	Drive adapter	1	AISI-316 stainless steel
18	Spring return cap washer	4	AISI-304 stainless steel
19	Nut	4	AISI-304 stainless steel
20	Pneumatic connection plate	1	Polyamide + FG
21	Plate allen screw	2	AISI-304 stainless steel
22	Watertightness plane gasket	1	N.B.R

1. Covered with polyamide.
2. Covered by cataphoresis.
3. Variable quantity, please see the Spring return torque chart.
4. Trivalent chromium passivation.
5. Polyurethane

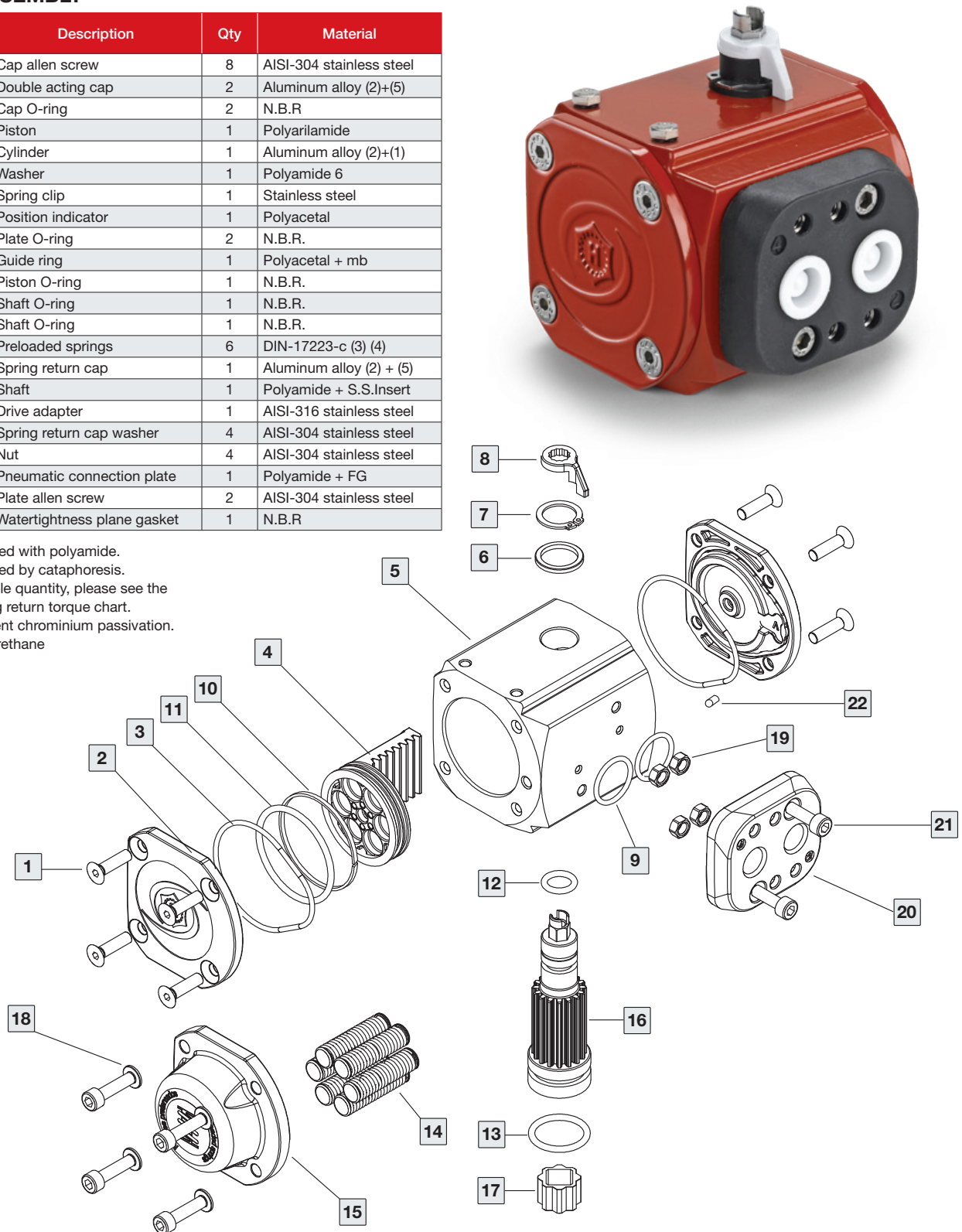

Model	Cycle time in (sec)		Weight		Capacity in litres	
	To open	To close	Kg.	Lb.	To open	To close
A1	0,1	0,1	0,65	1.43	0,07	0,03
A1S	0,15	0,15	0.72	1.58	0,07	

Cycle time w/o resistant torque at 6 bar.
Dimensions in mm.

To calculate the consumption, multiply the above figures by the real working pressure.

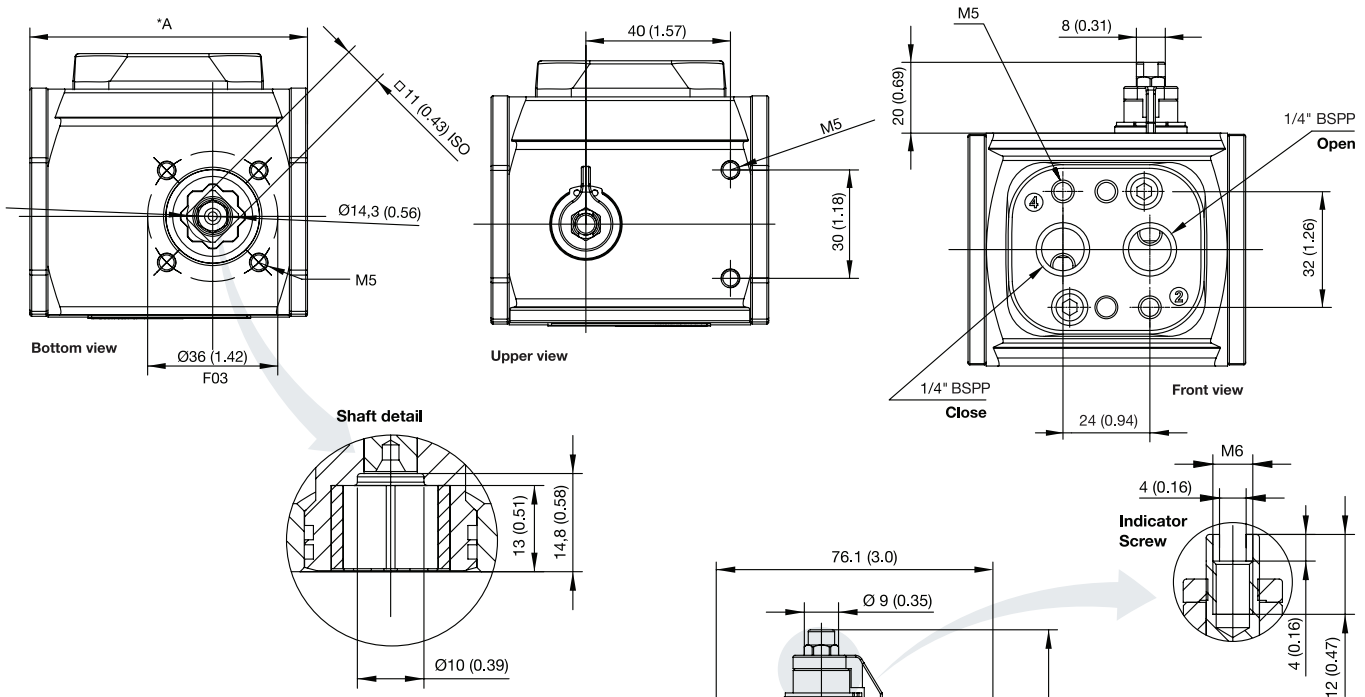

*For Spring Return Actuator: A = 96.5mm (3.8 inch)
For Double Acting Actuator: A = 76.8mm (3.02 inch)

DOUBLE ACTING TORQUES

A1	Air pressure						
Bar	3	4	5	5,5	6	7	8
PSI	43,5	58	72,5	79,8	87	101,5	116
Nm	4.0	5.5	7.0	7.7	8.5	9.8	11.2
Lb.in	35.4	48.7	62.0	68.2	75.2	86.7	99.1

SPRING RETURN TORQUES

A1S	Spring Torques		Air torque at indicated pressure														bar
			3		4		5		5,5		6		7		8		
			43,5	58	72,5	79,8	87	101,5	116	bar	p.s.i						
N	Initial	End	Initial	End	Initial	End	Initial	End	Initial	End	Initial	End	Initial	End	Initial	End	
6*	5.8	4					3	1.2	3.7	1.9	4.5	2.7	5.8	4	7.2	5.4	Nm
	51.3	35.6					26.4	10.6	32.6	16.8	39.7	23.9	51.2	35.4	63.5	47.8	Lb.in
5	4.9	3.4			2.1	0.6	3.6	2.1	4.3	2.8	5.1	3.6	6.4	4.9	7.8	6.3	Nm
	43.4	30.1			18.6	5.3	31.9	18.6	38.1	24.8	45.1	31.9	56.6	43.4	69	55.8	Lb.in
4	4	2.8			2.7	1.5	4.2	3	4.9	3.7	5.7	4.5	7	5.8	8.4	7.2	Nm
	35.6	24.4			24.3	13.1	37.5	26.3	43.7	32.5	50.8	39.6	62.3	51.1	74.7	63.5	Lb.in
3	3.2	2.1	1.9	0.8	3.4	2.3	4.9	3.8	5.6	4.5	6.4	5.3	7.7	6.6			Nm
	28	18.6	16.8	7.4	30.1	20.7	43.4	34	49.6	40.2	56.6	47.2	68.2	58.7			Lb.in
2	2.3	1.4	2.6	1.7	4.1	3.2	5.6	4.7	6.3	5.4	7.1	6.2					Nm
	20.4	12.4	23	15	36.3	28.3	49.6	41.6	55.8	47.8	62.8	54.9					Lb.in

N: Number of springs per side

* Standard number of springs

ALUMINUM PNEUMATIC ACTUATOR - TECHNICAL DATA

A2: DOUBLE ACTING

A2S: SPRING RETURN

DISASSEMBLY

No.	Description	QTY	Material
1	Cap allen screw	8	AISI-304 stainless steel
2	Double acting cap	2	Aluminum alloy (2)+(5)
3	Cap O-ring	2	N.B.R.
4	Piston	2	Polyarilamide
5	Cylinder	1	Aluminum alloy (2)+(1)
6	Washer	1	Polyamide 6
7	Spring clip	1	Stainless steel
8	Position indicator	1	Polyacetal
9	Plate O-ring	2	N.B.R.
10	Guide ring	2	Polyacetal + mb
11	Piston O-ring	2	N.B.R.
12	Shaft O-ring	2	N.B.R.
13	Shaft O-ring	2	N.B.R.
14	Preloaded springs	12	DIN-17223-c (3) (4)
15	Base plate (iso-5211)	1	Polyamide + FG
16	Shaft	1	Polyamide + S.S.Insert
17	Drive adapter	1	AISI-316 stainless steel
18	Cap washer	8	AISI-304 stainless steel
19	Allen screw	2	AISI-304 stainless steel
20	Nut	4	AISI-304 stainless steel
21	Nut	4	AISI-304 stainless steel
22	Pneumatic connection plate	1	Polyamide + FG
23	Plate allen screw	2	AISI-304 stainless steel
24	Spring return cap	2	Aluminum alloy (2)+(5)



1. Covered with polyamide.
2. Covered by cataphoresis.
3. Variable quantity, please see the Spring return torque chart.
4. Trivalent chromium passivation.
5. Polyurethane

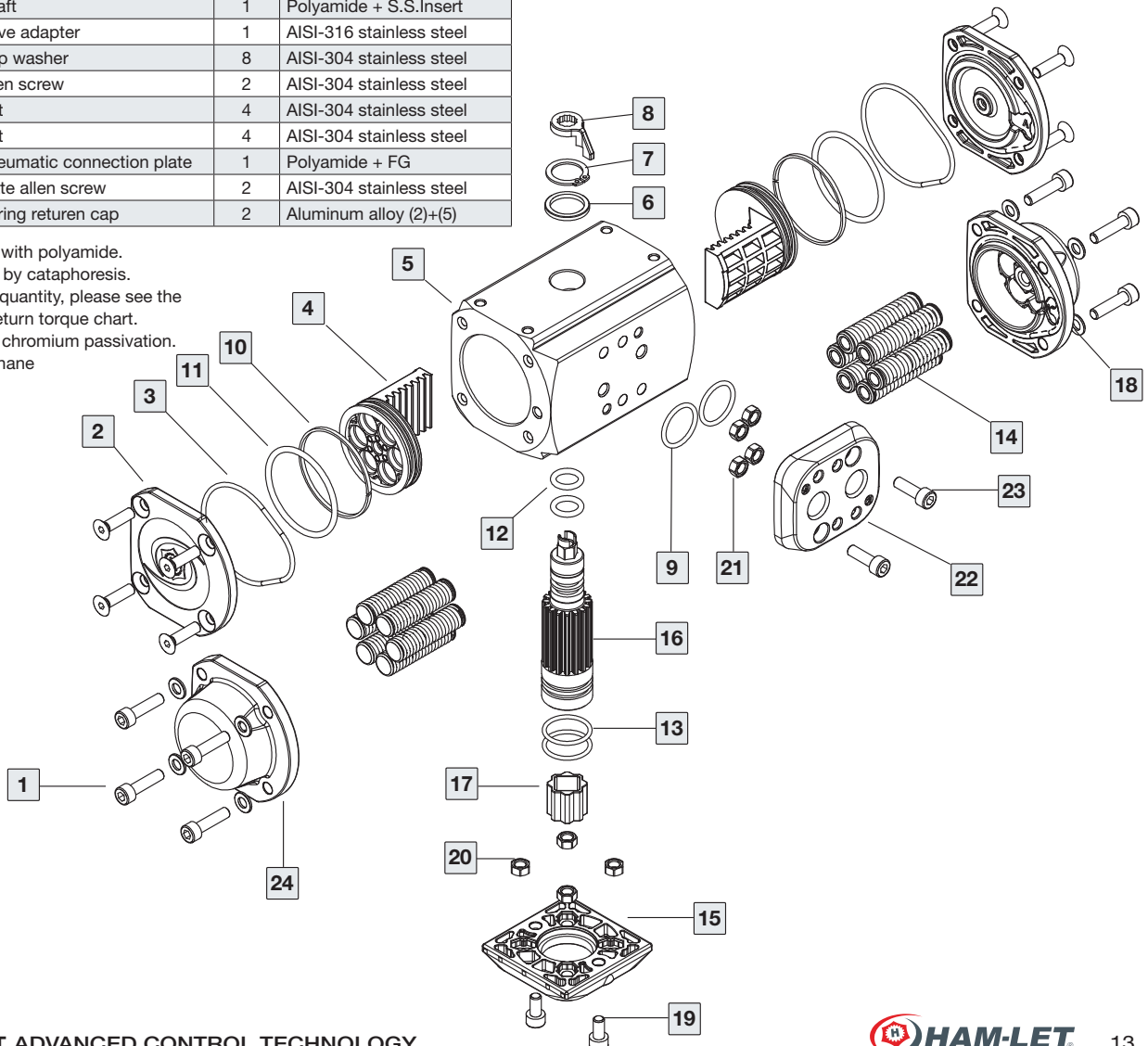

Model	Cycle time in (sec)		Weight		Capacity in litres	
	To open	To close	Kg.	Lb.	To open	To close
A2	0,1	0,1	0,92	2,02	0,075	0,11
A2S	0,15	0,15	1	2,20	0,075	

Cycle time w/o resistant torque at 6 bar.
Dimensions in mm.

To calculate the consumption, multiply the above figures by the real working pressure.

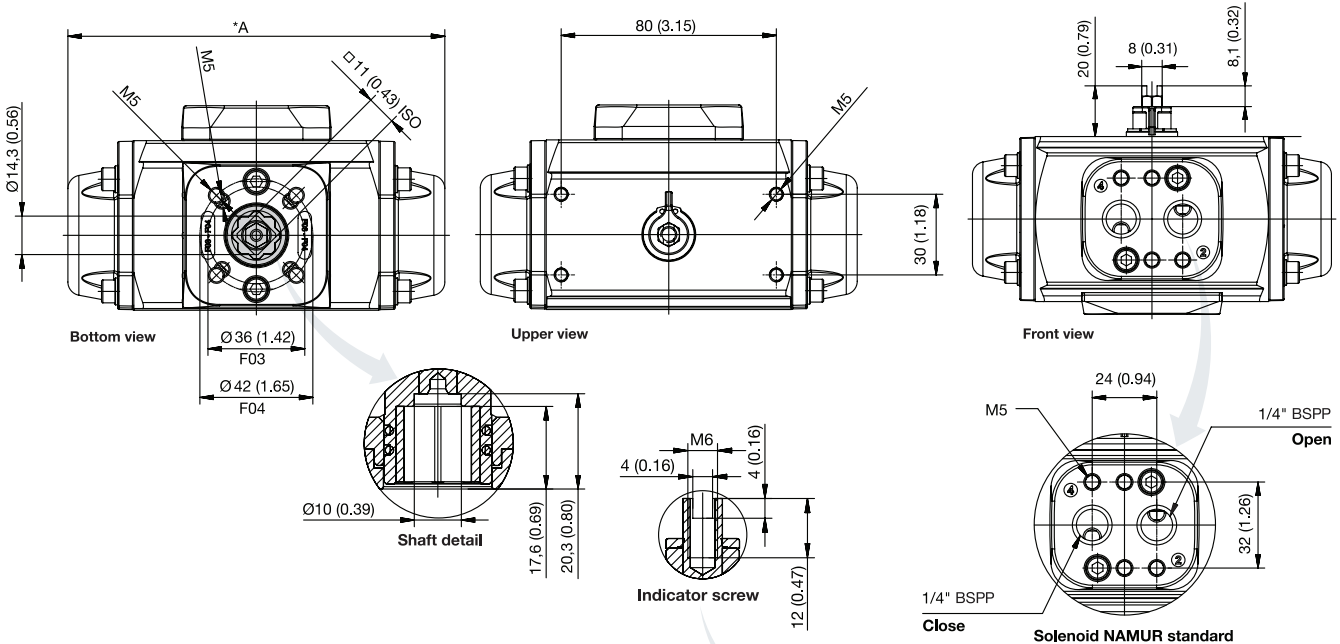

*For Spring Return Actuator: A = 140.2mm (5.5 inch)
For Double Acting Actuator: A = 101mm (3.97 inch)

DOUBLE ACTING TORQUES

A2	Air pressure						
	3	4	5	5,5	6	7	8
Bar	3	4	5	5,5	6	7	8
PSI	43,5	58	72,5	79,8	87	101,5	116
Nm	7,9	11,3	14,1	15,5	17	19,8	22,9
Lb.in	69,3	100	124,8	137,2	150,5	175,2	202,7

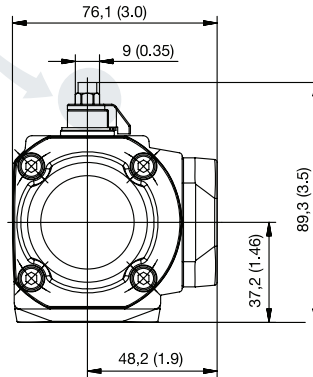

SPRING RETURN TORQUES

A2S	Spring Torques		Air torque at indicated pressure															
			3		4		5		5,5		6		7		8		bar	
			43,5	58	72,5	79,8	87	101,5	116									
N	Initial	End	Initial	End	Initial	End	Initial	End	Initial	End	Initial	End	Initial	End	Initial	End		
6*	10	6,7					7,4	4,1	8,8	5,5	10,3	7	13,1	9,8	16,2	12,9	Nm	
	88,5	59,3					65,5	36,3	77,9	48,7	91,2	62	115,9	86,7	143,4	114,2	Lb.in	
5	8,5	5,8			5,5	2,8	8,3	5,6	9,7	7	11,2	8,5	14	11,3	17,1	14,4	Nm	
	75,2	51,3			48,7	24,8	73,5	49,6	85,9	62	99,1	75,2	123,9	100	151,3	127,5	Lb.in	
4	7	4,6	3,3	0,9	6,7	4,3	9,5	7,1	10,9	8,5	12,4	10	15,2	12,8	18,3	15,9	Nm	
	62	40,7	29,2	8	59,3	38,1	84,1	62,8	96,5	75,2	109,7	88,5	134,5	113,3	162	140,7	Lb.in	
3	5,5	3,6	4,3	2,4	7,7	5,8	10,5	8,6	11,9	10	13,4	11,5	16,2	14,3			Nm	
	48,7	31,9	38,1	21,2	68,2	51,3	92,9	76,1	105,3	88,5	118,6	101,8	143,4	126,6			Lb.in	
2	4	2,4	5,5	3,9	8,9	7,3	11,7	10,1	13,1	11,5	14,6	13					Nm	
	35,4	21,2	48,7	34,5	78,8	64,6	103,6	89,4	115,9	101,8	129,2	115,1					Lb.in	

N: Number of springs per side

* Standard number of springs

ALUMINUM PNEUMATIC ACTUATOR - TECHNICAL DATA

A3: DOUBLE ACTING

A3S: SPRING RETURN

DISASSEMBLY

No.	Description	Qty	Material
1	Cap allen screw	8	AISI-304 stainless steel
2	Cap	2	Aluminum alloy (2) + (6)
3	Cap-O-ring	2	N.B.R.
4	Piston	2	Aluminum alloy (2)
5	Cylinder	1	Aluminum alloy (2) + (1)
6	Washer	1	Polyamide 6
7	Spring clip	1	Steel (3)
8	Position indicator	1	Polyamide
9	Piston guide	2	Polyacetal
10	Guide ring	2	Polyacetal
11	Piston O-ring	2	N.B.R.
12	Shaft O-ring	2	N.B.R.
13	Shaft O-ring	2	N.B.R.
14	Preloaded springs	12	DIN-17223-c (5) (4)
15	Base plate (iso-5211)	1	Polyamide + FG
16	Shaft	1	Steel (2)
17	Cam	1	Steel (2)
18	Cap washer	8	AISI-304 stainless steel
19	Allen screw	2	AISI-304 stainless steel
20	Nut	4	AISI-304 stainless steel
21	Plate O-ring	2	N.B.R.
22	Nut	4	AISI-304 stainless steel
23	Pneumatic connection plate	1	Polyamide + FG
24	Plate allen screw	2	AISI-304 stainless steel
25	Hexagonal screw	2	AISI-304 stainless steel
26	Nut	2	AISI-304 stainless steel
27	Bushing	2	AISI-303 stainless steel
28	O-ring	2	N.B.R.



1. Covered with polyamide.
2. Covered by cathoporesis.
3. Covered by nickel - PTFE.
4. Variable quantity, please see the Spring return torque chart.
5. Trivalent chromium passivation.
6. Covered with polyurethane.

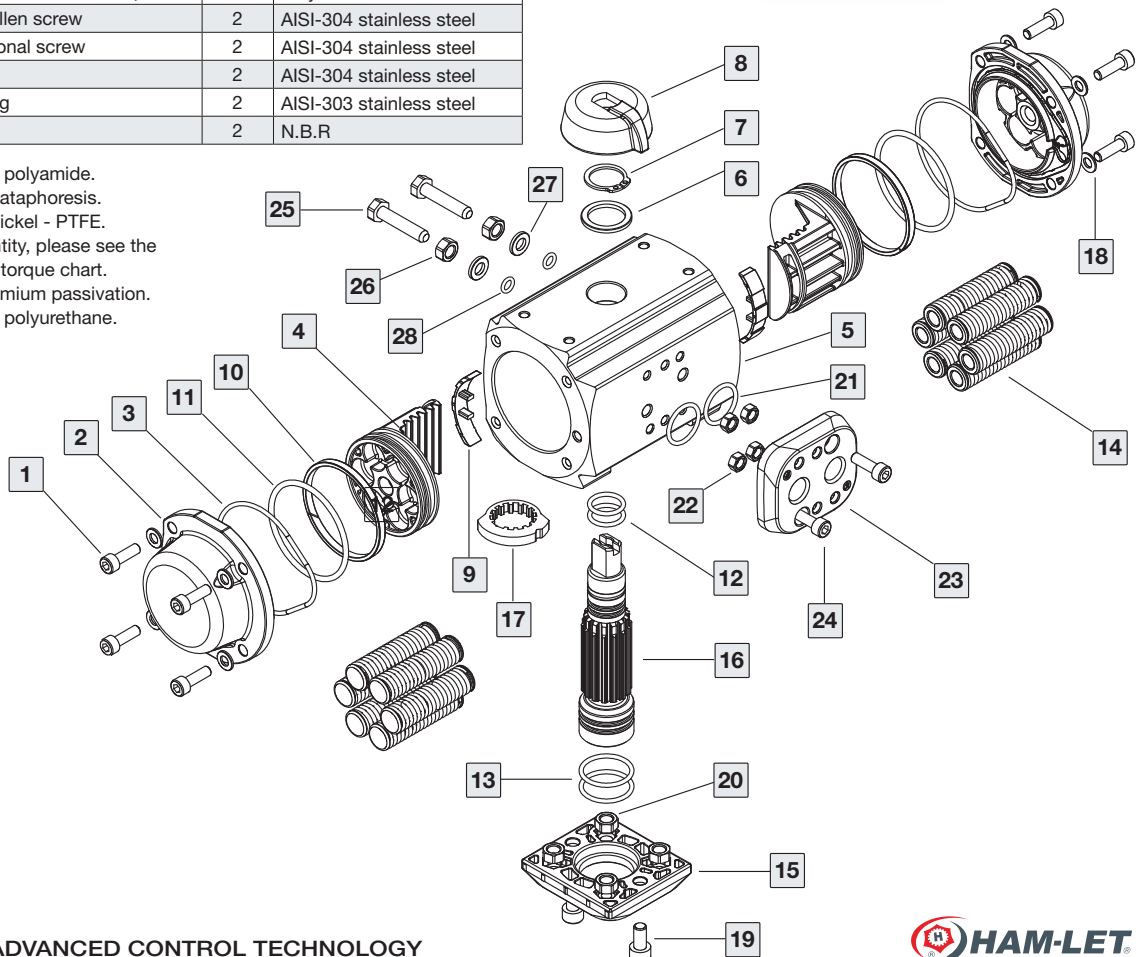

Model	Cycle time in (sec)		Weight		Capacity in litres	
	To open	To close	Kg.	Lb.	To open	To close
A3	0,15	0,15	1.40	3.09	0,15	0,18
A3S	0,2	0,2	1.625	3.58	0,15	

Cycle time w/o resistant torque at 6 bar.
Dimensions in mm.

To calculate the consumption, multiply the
above figures by the real working pressure.

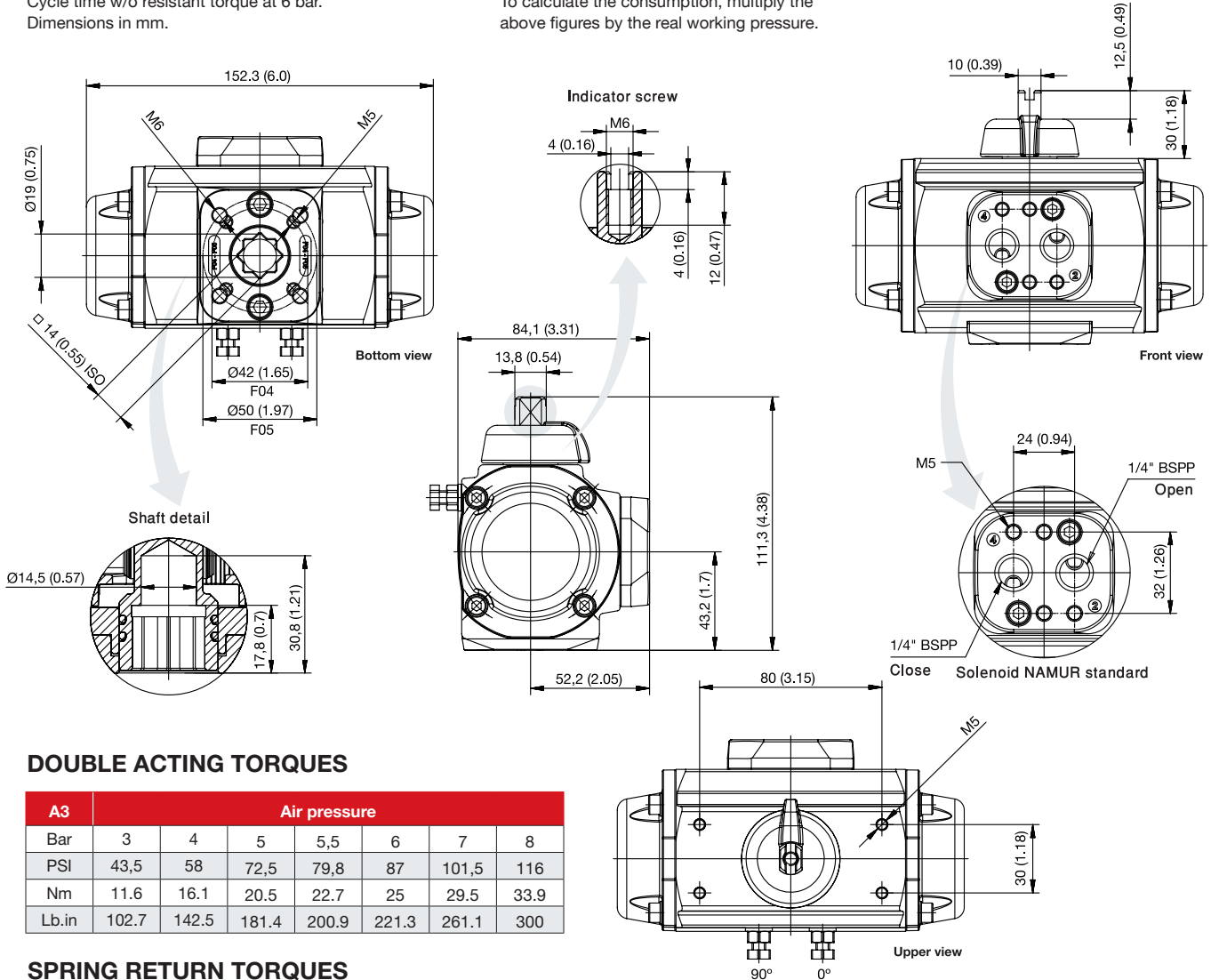

DOUBLE ACTING TORQUES

A3	Air pressure						
Bar	3	4	5	5,5	6	7	8
PSI	43,5	58	72,5	79,8	87	101,5	116
Nm	11.6	16.1	20.5	22.7	25	29.5	33.9
Lb.in	102.7	142.5	181.4	200.9	221.3	261.1	300

SPRING RETURN TORQUES

A3S	Spring Torques		Air torque at indicated pressure														
			3		4		5		5,5		6		7		8		bar
			43,5	58	72,5	79,8	87	101,5	116	p.s.i							
N	Initial	End	Initial	End	Initial	End	Initial	End	Initial	End	Initial	End	Initial	End	Initial	End	
6*	16,5	11,1					9,4	4	11,6	6,2	13,9	8,5	18,4	13	22,8	17,4	17,4Nm
	146	98,2					83,2	35,4	102,7	54,9	123	75,2	162,9	115,1	201,8	154	Lb.in
5	13,8	9,4			6,7	2,3	11,1	6,7	13,3	8,9	15,6	11,2	20,1	15,7	24,5	20,1	Nm
	122,1	83,2			59,3	20,4	98,2	59,3	117,7	78,8	138,1	99,1	177,9	139	216,8	177,9	Lb.in
4	11,1	7,6			8,5	5	12,9	9,4	15,1	11,6	17,4	13,9	21,9	18,4	26,3	22,8	Nm
	98,2	67,3			75,2	44,3	114,2	83,2	133,6	102,7	154	123	177,9	162,9	232,8	201,8	Lb.in
3	8,5	5,8	5,8	3,1	10,3	7,6	14,7	12	16,9	14,2	19,2	16,5	23,7	21			Nm
	75,2	51,3	51,3	27,4	91,2	67,3	130,1	106,2	149,6	125,7	169,9	146	209,8	185,9			Lb.in
2	5,8	3,6	8	5,8	12,5	10,3	16,9	14,7	19,1	16,9	21,4	19,2					Nm
	51,3	31,9	70,8	51,3	110,6	91,2	149,6	130,1	169	149,6	189,4	169,9					Lb.in

N: Number of springs per side

* Standard number of springs

ALUMINUM PNEUMATIC ACTUATOR - TECHNICAL DATA

A4: DOUBLE ACTING

A4S: SPRING RETURN

DISASSEMBLY

No.	Description	Qty	Material
1	Cap allen screw	8	AISI-304 stainless steel
2	Cap	2	Aluminum alloy (2) + (6)
3	Cap-O-ring	2	N.B.R.
4	Piston	2	Aluminum alloy (2)
5	Cylinder	1	Aluminum alloy (2) + (1)
6	Washer	1	Polyamide 6
7	Spring clip	1	Steel (3)
8	Position indicator	1	Polyamide
9	Piston guide	2	Polyacetal
10	Guide ring	2	Polyacetal
11	Piston O-ring	2	N.B.R.
12	Shaft O-ring	2	N.B.R.
13	Shaft O-ring	2	N.B.R.
14	Preloaded springs	12	DIN-17223-c (5) (4)
15	Cam	1	Steel (2)
16	Shaft	1	Steel (2)
17	Plate O-ring	2	N.B.R.
18	Cap washer	8	AISI-304 stainless steel
19	Nut	4	AISI-304 stainless steel
20	Pneumatic connection plate	1	Polyamide + FG
21	Plate allen screw	2	AISI-304 stainless steel
22	Hexagonal Screw	2	AISI-304 stainless steel
23	Nut	2	AISI-304 stainless steel
24	Bushing	2	AISI-304 stainless steel
25	O-ring	2	N.B.R.

1. Covered with polyamide.
2. Covered by cataphoresis.
3. Covered by nickel - PTFE
4. Variable quantity, please see the Spring return torque chart.
5. Trivalent chromium passivation.
6. Covered with polyurethane.

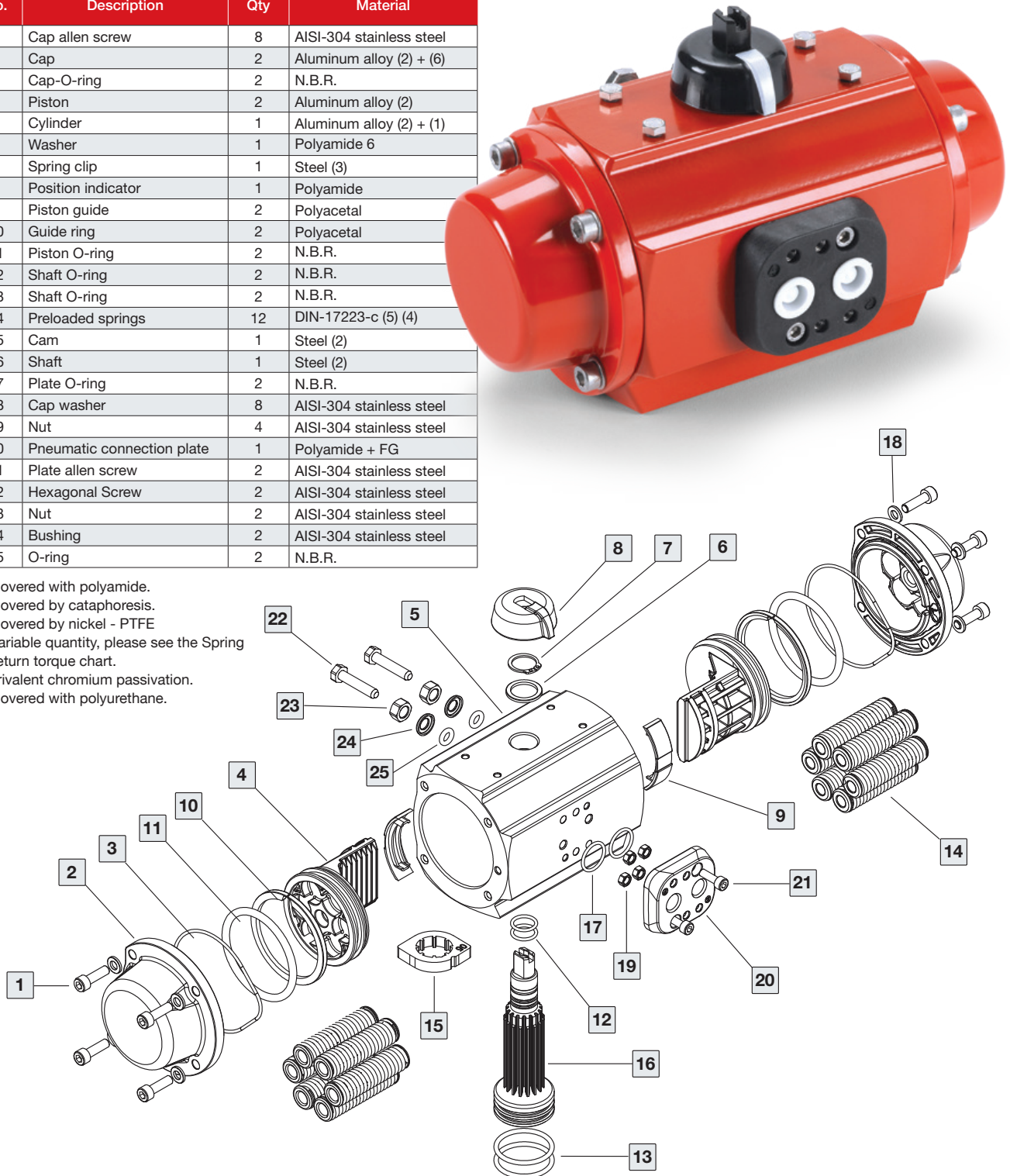

Model	Cycle time in (sec)		Weight		Capacity in litres	
	To open	To close	Kg.	Lb.	To open	To close
A4	0.2	0,2	2.57	5.67	0,28	0.37
A4S	0,25	0,25	2.94	6.49	0,28	

Cycle time w/o resistant torque at 6 bar.
Dimensions in mm.

To calculate the consumption, multiply the above figures by the real working pressure.

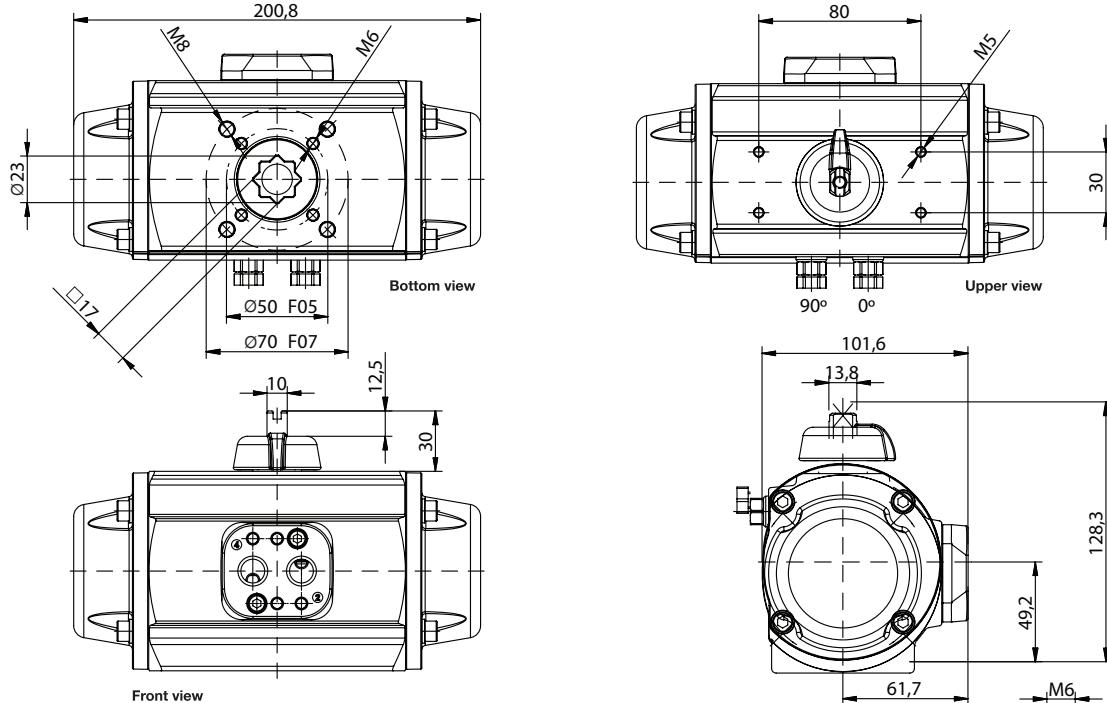

DOUBLE ACTING TORQUES

A4	Air pressure						
Bar	3	4	5	5,5	6	7	8
PSI	43,5	58	72,5	79,8	87	101,5	116
Nm	23.5	32.3	41.0	45.3	49.7	58.4	67.1
Lb.in	280	286	363	401	440	517	594

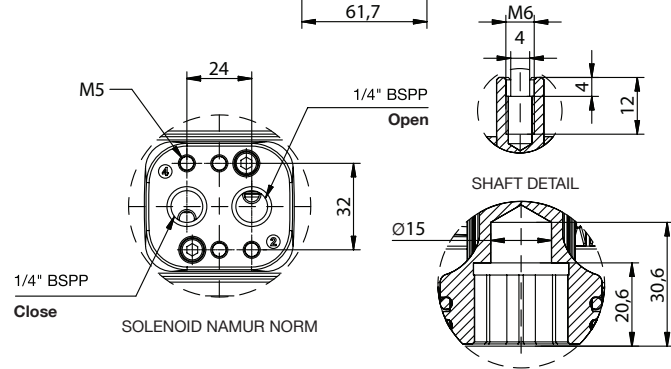

SPRING RETURN TORQUES

A4S	Spring Torques		Air torque at indicated pressure														
			3		4		5		5,5		6		7		8		bar
			43,5	58	72,5	79,8	87	101,5	116								
N	Initial	End	Initial	End	Initial	End	Initial	End	Initial	19,4	Initial	End	Initial	End	Initial	End	
6*	31.4	20.9					20.1	9.6	24.4	13.9	28.8	18.3	37.5	27.0	46.2	35.7	Nm
	277.9	185					177.9	85.0	216	123	254.9	162	331.9	239	408.9	316	Lb.in
5	27	17.4			14.9	5.3	23.6	14	27.9	18.36	32.3	22.7	41	31.4	49.7	41	Nm
	239	154			131.9	46.9	208.9	123.9	246.9	162	285.9	200.9	362.9	277.9	439.9	354.9	Lb.in
4	21.8	13.9	9.6	1.7	18.4	10.5	27.1	19.2	31.4	23.5	35.8	27.9	44.5	36.6	53.2	54.3	Nm
	192.9	123	85	15	162.9	92.9	239.9	169.9	277.9	208	316.9	246.9	393.9	323.9	470.9	400.9	Lb.in
3	18.3	11.3	12.2	5.2	21	14	29.7	22.7	34	27	38.4	31.4	47.1	40.1			Nm
	162	100	108	46	185.9	123.9	262.9	200.9	300.9	239	339.9	277.9	416.9	354.9			Lb.in
2	12.2	7.8	15.7	11.3	24.5	20.1	33.2	28.8	37.5	33.1	41.9	37.5					Nm
	108	69	139	100	216.8	177.9	293.8	254.9	331.9	293	370.8	331.9					Lb.in

N: Number of springs per side

* Standard number of springs

180° PNEUMATIC ACTUATOR - TECHNICAL DATA

DISASSEMBLY

No.	Description	Qty	Material
1	Cap screw	8	AISI-304 stainless steel
2	Duabel acting cap	2	Aluminium alloy (2) + (4)
3	Cap O-ring	2	N.B.R.
4	Piston	2	Aluminium alloy (2)
5	Cylinder	1	Aluminium alloy (2) + (1)
6	Washer	1	Polyamide 6
7	Spring clip	1	Stainless Steel (3)
8	Position indicator	1	Polyacetal
9	Piston guide	2	Polyacetal
10	Guide ring	2	Polyacetal + Mb
11	Piston O-ring	2	N.B.R.
12	Shaft O-ring	2	N.B.R.
13	Shaft O-ring	2	N.B.R.
14	Springs set	2	DIN-17223-c (2) (3)
15	Base plate (ISO-5211)	1	Polyamide + FG
16	Shaft	1	Polyamide + S.S. Insert
17	Drive adapter	1	AISI-316 stainless steel
18	Cap washer	8	AISI-304 stainless steel
19	Allen screw	2	AISI-304 stainless steel
20	Nut	4	AISI-304 stainless steel
21	Nut	4	AISI-304 stainless steel
22	Pneumatic connection plate	1	Polyamide + FG
23	Plate allen screw	2	AISI-304 stainless steel
24	Plate O-ring	2	N.B.R.
25	Spring return cap	2	Aluminium alloy (2) + (4)

A2T: DOUBLE ACTING



A2ST: SPRING RETURN



- (1) Covered with polyamide.
- (2) Covered by Cataphoresis.
- (3) Variable quantity, please see the Spring return torque chart.
- (4) Covered with polyurethane.

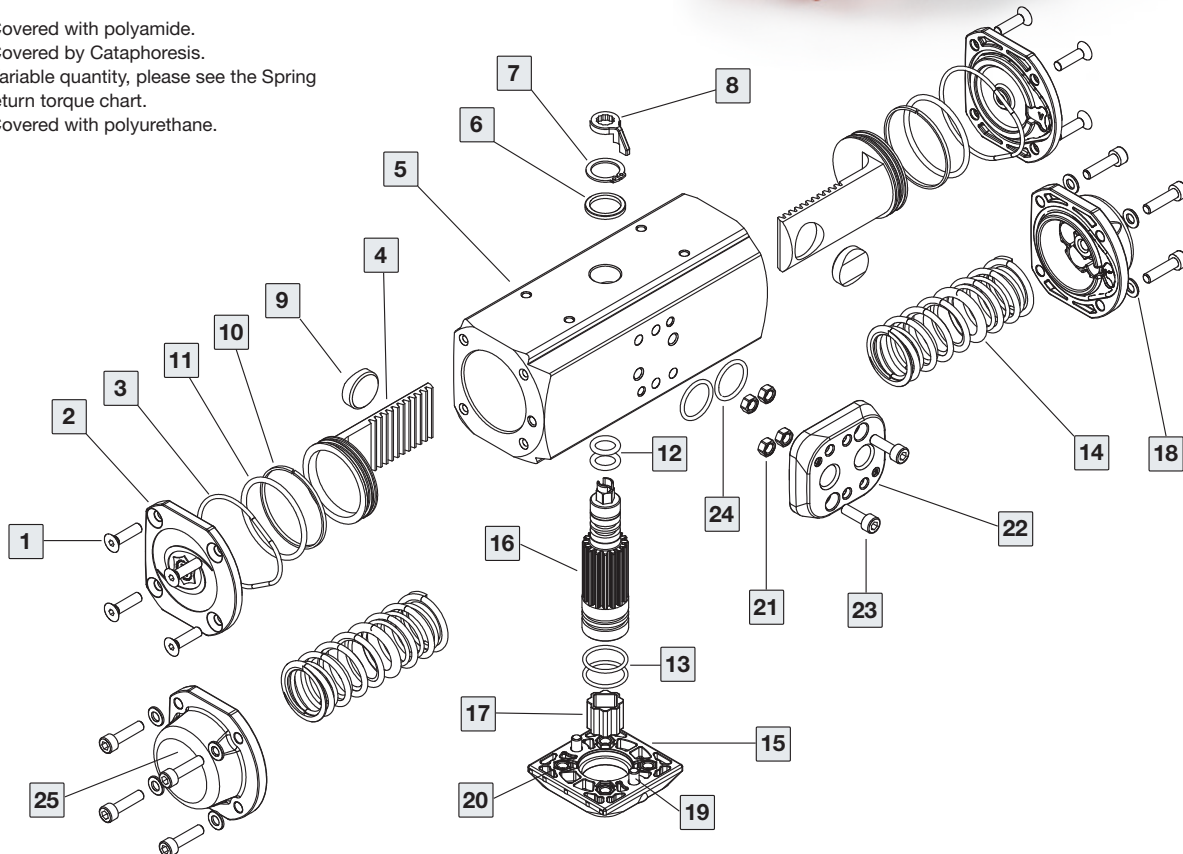

Model	Cycle time in (sec)		Weight		Capacity in litres	
	To open	To close	Kg.	Lb.	To open	To close
A2T	0.13	0.13	1.3	2.76	0.123	0.158
A2ST	0.20	0.20	1.5	3.31	0.123	

Cycle time w/o resistant torque at 6 bar.
Dimensions in mm.

To calculate the consumption, multiply the above figures by the real working pressure.

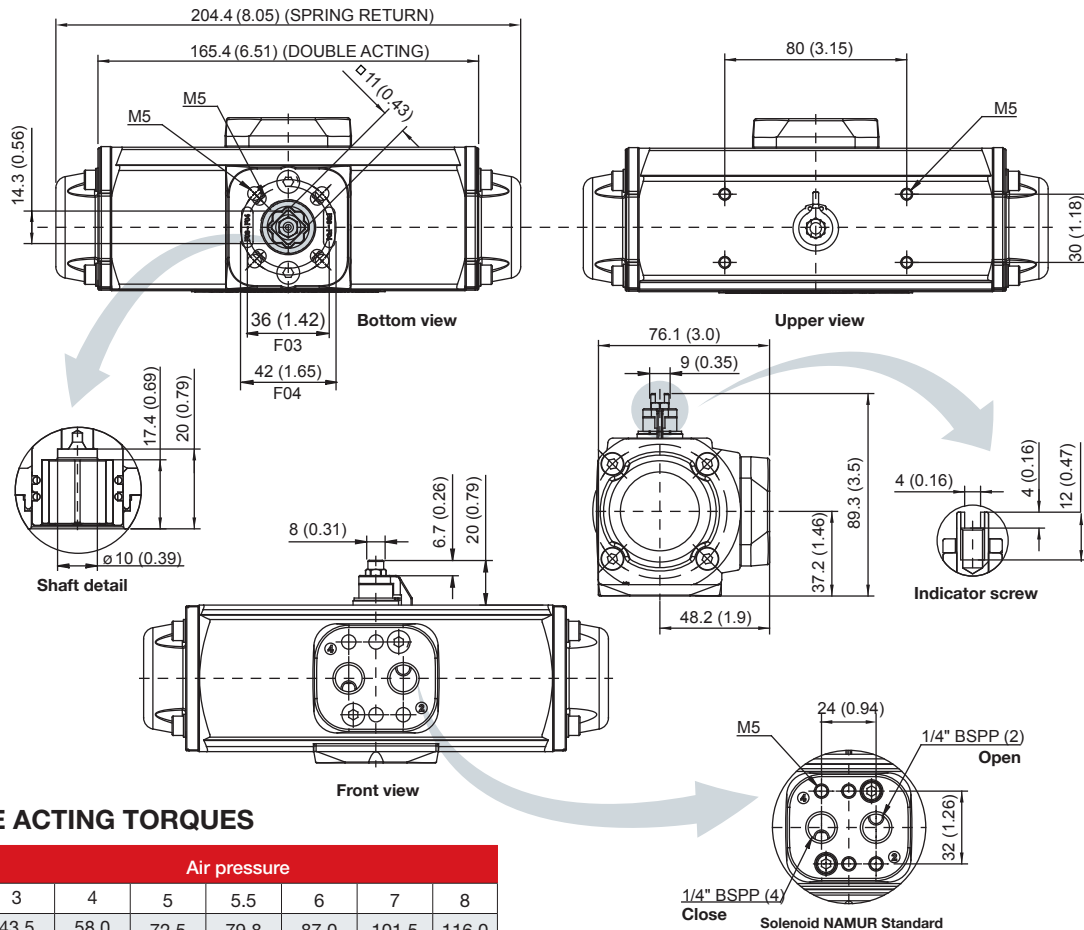

DOUBLE ACTING TORQUES

A2T	Air pressure						
Bar	3	4	5	5.5	6	7	8
PSI	43.5	58.0	72.5	79.8	87.0	101.5	116.0
Nm	7.9	11.3	14.1	15.5	17.0	19.8	22.9
Lb.in	69.9	100	124.8	137.2	150.5	175.2	202.7

SPRING RETURN TORQUES

A2ST	Spring Torques		Air torque at indicated pressure														
			3		4		5		5.5		6		7		8		bar
			43.5	58	72.5	79.8	87	101.5	116								
N	Initial	End	Initial	End	Initial	End	Initial	End	Initial	End	Initial	End	Initial	End	Initial	End	
4*	9.7	6.1					8	4.4	9.4	5.8	10.9	7.3	13.7	10.1	16.8	13.2	Nm
	86.1	53.8					71	38.7	83.4	51.1	96.6	64.3	121.4	89.1	148.9	116.6	Lb.in
3	8.8	5.5			5.8	2.5	8.6	5.3	10	6.7	11.5	8.2	14.3	11	17.4	14.1	Nm
	78.1	48.4			51.6	21.9	76.4	46.7	88.8	59.1	102	72.4	126.8	97.2	154.3	124.6	Lb.in
2	6.7	4.3	3.6	1.2	7	4.6	9.8	7.4	11.2	8.8	12.7	10.3	15.5	13.1			Nm
	59	37.7	32.2	10.7	62.3	40.8	87.1	65.6	99.5	78	112.8	91.3	137.5	116			Lb.in
1	4.3	2.4	5.5	3.6	8.9	7	11.7	9.8	13.1	11.2	14.6	12.7					Nm
	37.7	21.5	48.4	32.2	78.5	62.3	103.3	87.1	115.7	99.5	129	112.8					Lb.in

N: Number of springs per side

* Standard number of springs

ACCESSORIES KITS



Standard 90 degrees. Aluminum pneumatic actuator, Operating Pressure: max. 8 bar (116 PSI). Standard working temperature -32°C to 90°C (-25.6°F to 194°F)



Inductive limit switch for visual and electric indication of actuator position voltage: 8V DC, Enclosure IP67



Electric actuator has been designed to control valve with 90 deg rotation 15W, IP66.
Option 1: 90-240V, 50/60HZ, 90-350V DC,
Option 2: 15-30V, 50/60HZ, 12-48V DC



Solenoid valve, attached to the actuator to create an electro pneumatically actuated ball valve. DC 24V, 2.5W 4/2 Way for double acting and spring return. Enclosure IP65
Option for: 110VAC, 50HZ.
Option for: 3/2, 5/2 Way.

For more information please contact your local representative.



ATEX mechanical limit switch for use in hazardous locations zone 2, temp range (-20°C to 60°C) (-4°F to 140°F)

(ATEX Inductive limit switch is available as an option).



Electro Mechanical limit switch for visual and electric indication of actuator position. Enclosure IP67,
voltage: AC: 250V 16A, 125V 16A
DC: 250V 0.3A, 125V 0.6A, 30V 10V

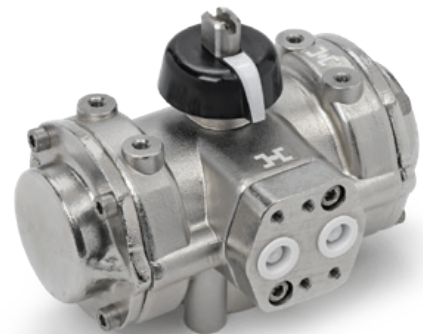

90 degree Stainless Steel pneumatic actuator, operating pressure max. 8 bar (116 PSI). Standard working temperature -32°C to 90°C (-25.6°F to 194°F)

Ordering information for Factory Assembled Accessories

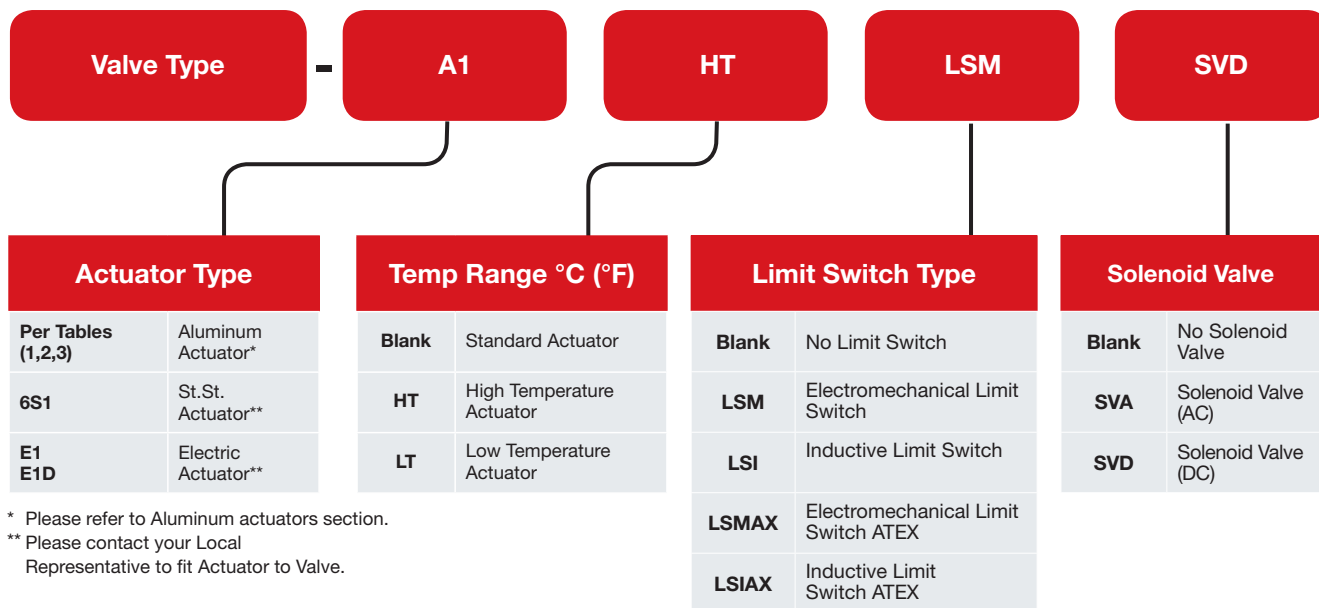

* Please refer to Aluminum actuators section.
 ** Please contact your Local Representative to fit Actuator to Valve.

Mounting Kits for field assembly of Limit Switches:	
Actuator Type	Mounting Kit Description
A1 /A1S	Z-LS-MK-A1
A2 /A2S	Z-LS-MK-A2
A3 /A3S	Z-LS-MK-A3
A4 /A4S	Z-LS-MK-A4

- If special cleaning is required, LF / OC will be added in the end, and will refer to the Valve Only.
 For example: **H - 800S-SS - L- 1/4 - A1-LSM - OC**
- In case of request for Actuated valve with LS and Solenoid Valve, The order is as follows: Valve, Actuator, LS, Solenoid
 For example: **H - 800S-SS - L- 1/4 - A1-LSM-SVD**
- For double mounting actuators, please contact your local representative.

Ordering Information for Accessories Kits for field assembly

Aluminum actuators for field assembly	Electro Mechanical Limit Switch	Inductive Limit Switch (Contains one inductive limit switch)	Electro Mechanical /Inductive Limit Switch ATEX	Stainless Steel Actuator*	Electric Actuator*	Solenoid Valve 4/2 Way Option: 5/2, 3/2 Way
See Tables (1,2,3)	Z - LSM	Z - LSI	Z - LSMAX Z - LSIAX	Z - 6S1	Z - E1A (AC) Z - E1D (DC)	Z - SVA (AC) Z - SVD (DC)

* For Stainless Steel Actuator or Electric Actuator Please contact your local representative.

Warning! For your safety

The system designer and user have the sole responsibility for selecting products suitable for their special application requirements, ensuring their safe and trouble-free installation, operation, and maintenance. Application details, material compatibility and product ratings should all be considered for each selected product. Improper selection, installation or use of products can cause property damage or personal injury.

HPA | 2019_Rev00