

Forbes Marshall Moisture Separator - Flanged

Description

The Forbes Marshall Moisture Separator, FMSEP54, is a carbon steel baffle type separator used for the removal of entrained liquids in steam, so that they can be drained away as condensate.

Sizes and Connections

Sizes: DN 25, 40, 50, 65, 80, 100, 125, 150 and 200

Flange Connections

BS 10 Table F, H, J, K, ASME B 16.5
Class 150, 300, PN 10, 16, 25 and 40

Notes : Available with IBR test certificates, on request.
Optional insulation packs are available which will increase the performance of the separator.

Limiting Conditions

Body design condition	32 bar g at 425 °C
Cold hydraulic test pressure	64 bar g

Flange Types	Max. Working Pressure	Max. Working Temp.
TAB 'F'	21 bar g at 232 °C	425 °C at 10.5 bar g
TAB 'H'	32 bar g at 232 °C	425 °C at 17 bar g
TAB 'J'	32 bar g at 232 °C	425 °C at 24 bar g
TAB 'K'	32 bar g at 232 °C	425 °C at 31 bar g
ASA 150	19.6 bar g at 38 °C	425 °C at 5.5 bar g
ASA 300	51.1 bar g at 38 °C	425 °C at 28.8 bar g
PN 10	10 bar g at 200 °C	425 °C at 5.65 bar g
PN 16	16 bar g at 200 °C	425 °C at 9.1 bar g
PN 25	25 bar g at 200 °C	425 °C at 14.25 bar g
PN 40	40 bar g at 200 °C	425 °C at 22.8 bar g

Operating Range

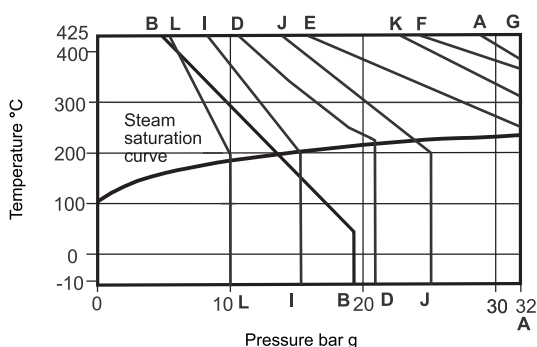

A-A Flanged ANSI 300	G-A BS10 Table K
B-B Flanged ANSI 150	L-L PN 10
D-D BS10 Table F	I-I PN 16
E-A BS10 Table H	J-J PN 25
F-A BS10 Table J	K-A PN 40

Dimensions: (approx.) in mm

Sizes DN	Dimensions				Weight Kg
	A	B	C	E	
25	280	70	100	20 DN	14
40	390	89	111	20 DN	22
50	472	120.5	146	25 DN	32
65	405	146	171	20 DN	40
80	510	152.4	174	25 DN	69
100	720	200	238	25 DN	114
125	705	354	233	25 DN	184
150	720	375	232	25 DN	200
200	762	416	308	40 DN	300

General Tolerance: ±3

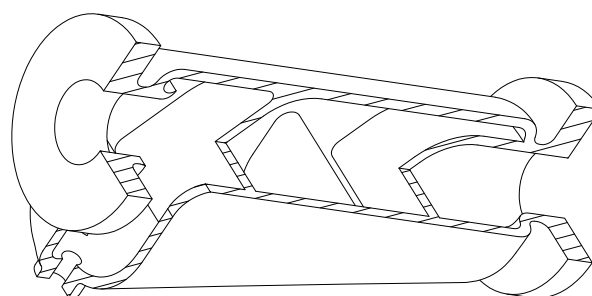
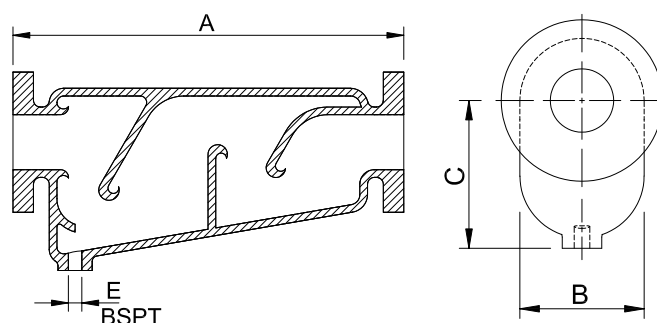

How to Order

Example: 1 no. DN 40 Forbes Marshall Moisture Separator C.S. FMSEP54 Flanged BS 10 Table "K" IBR

Installation

Install in a horizontal pipeline with the drain directly below.

Note: To ensure that any separated liquid is drained away quickly, a suitable steam trap must be connected to the drain connection. Consult Forbes Marshall for further details.



Forbes Marshall
B-85, Phase II, Chakan Industrial Area
Sawardari, Chakan
Tal. Khed, Dist. Pune 410501. INDIA.
Tel : +91 02135 393400

Forbes Marshall Steam Systems Pvt. Ltd.
(Formerly Spirax Marshall Pvt. Ltd.)
Regd Office: Opp 106th Milestone
Bombay Poona Road, Kasarwadi,
Pune 411 034. INDIA.
Tel.: 91(0)20-27145595, 39858555
CIN No : U27109PN1959PTC011334



Email : seg@forbesmarshall.com

www.forbesmarshall.com