



# HTL Ultra-Low Torque Wrench Link Attachment

The HTL Ultra-Low Torque Wrench Link Attachment is part of HTL's innovative 3-in-1 Hydraulic Torque Wrench range. Due to its innovative design and the high quality materials used, this tool is extremely durable and easy to operate. With both ring and open end spanner attachments available providing various hex sizes ranging from 3/4" to 4 5/8" AF (19mm to 120mm AF) and torque ranges from 255 to 13400 ft.lb (346 to 18165 Nm), the HTL Ultra-Low Torque Wrench Link Attachment is suitable for a wide range of applications even on the most confined applications.

## Interchangeable and Cross Compatible

The 3-in-1 range ensures that the operator can interchange tools and links with many other well-known brands (specifically Hytorc, Rapid-Torc and Atlas Copco).

Please note a complete HTL Ultra-Low Torque Wrench is made up of a HTL Torque Wrench and HTL Ultra-Low Torque Wrench Attachment, each are sold separately.

## Features and Benefits

- ✓ Fully interchangeable with many other brands
- ✓ Made in the UK
- ✓ Calibrated and Accurate to +/- 3%
- ✓ Only 3 moving parts for reliability and maintenance
- ✓ Convert to a Low Profile or Square Drive tool in seconds
- ✓ Ring and Open end spanner attachments available
- ✓ Non-standard sizes manufactured to your specification
- ✓ Supplied with link pin retainer
- ✓ Ergonomic, adjustable torque wrench handle



# Technical Information

Model		HTL-W2 & HTL-R2	HTL-W4 & HTL-R4	HTL-W8 & HTL-R8	HTL-W14 & HTL-R14
<b>Torque wrench</b>		HTL-W2	HTL-W4	HTL-W8	HTL-W14
<b>Min Torque</b>	<b>Ft-lbs</b>	255	580	1143	2010
	<b>Nm</b>	346	786	1549	2725
<b>Max Torque</b>	<b>Ft-lbs</b>	1710	3855	8151	13400
	<b>Nm</b>	2318	5226	11049	18165
<b>Weight</b>	<b>Kg</b>	2.2	3	3.3	8.2
<b>A</b>	<b>mm</b>	155	208	260	349
	<b>Inch</b>	6.1	8.1	10.2	13.7
<b>B</b>	<b>mm</b>	129	168	209	239
	<b>Inch</b>	5.1	6.6	8.2	9.4
<b>C</b>	<b>mm</b>	66	87	108	132
	<b>Inch</b>	2.6	3.4	4.3	5.1
<b>D</b>	<b>mm</b>	32	42	53	64
	<b>Inch</b>	1.2	1.7	2.1	2.52
<b>E</b>	<b>mm</b>	19	25.4	31.75	39
	<b>Inch</b>	0.7	1	1.25	1.5
<b>F</b>	<b>mm</b>	7.5	7.5	13	17.5
	<b>Inch</b>	0.3	0.3	0.5	0.7
<b>AF</b>	<b>mm</b>	19-65	32-80	46-100	50-120
	<b>Inch</b>	$\frac{3}{4}$ " - $2 \frac{9}{16}$ "	$1 \frac{5}{16}$ " - $3 \frac{1}{8}$ "	$1 \frac{13}{16}$ " - $3 \frac{7}{8}$ "	$2$ " - $4 \frac{5}{8}$ "

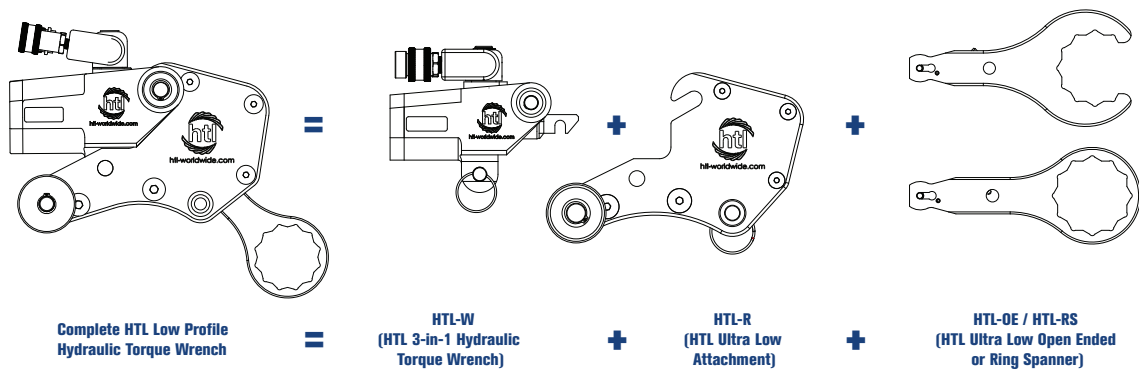
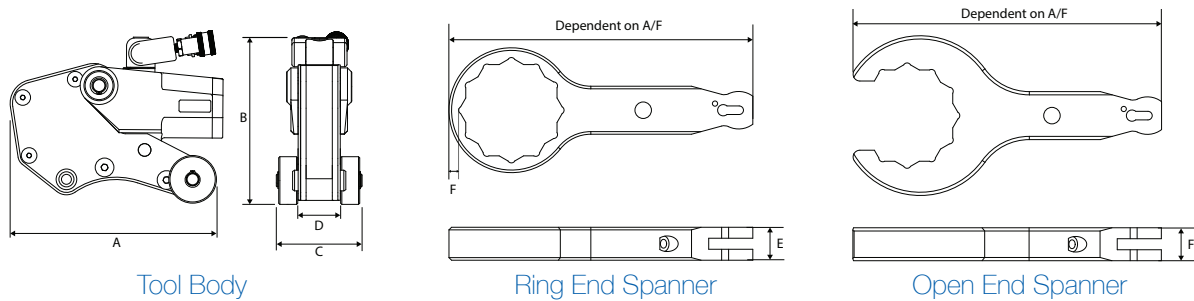

PLEASE NOTE: Figures provided are for guidance only, please refer to individual tool charts. All data is given in good faith and without acceptance of responsibility on the part of HTL.

**INDUSTRY LEADERS IN CONTROLLED BOLTING, FLANGE WORKING AND PORTABLE MACHINE SOLUTIONS**



Hire Torque Ltd  
45 Colbourne Avenue,  
Nelson Park Industrial Estate,  
Cramlington, Northumberland,  
NE23 1WD



Telephone: +44 (0) 1670 700 000  
Email: info@hiretorque.com  
Visit: www.hiretorque.com

