



HTL Hydraulic Torque Pump with Oil Cooler

The HTL Hydraulic Torque Pump with Oil Cooler is the ideal solution for locations with a high ambient temperature, ensuring extended working time and allowing projects to be completed efficiently.

Available in 110V or 220V models, the pump's integrated Oil Cooler utilises an 8" electric fan and 100% aluminium tube and fin construction offering excellent cooling performance when compared to other Electric Torque Pumps without cooling fans.

Offering a lightweight and portable solution which has been designed to be user friendly ensuring ease of use for the operator whilst offering maximum efficiency.

With a maximum operating pressure of 10,000 psi / 700 bar and a precision pressure regulating valve, HTLs range of torque pumps can be used with most leading brands of hydraulic torque tools.

Incorporating a compact solenoid valve system, protective frame and precision calibrated pressure gauge the HTL Hydraulic Torque Pump with Oil Cooler is supplied with a four tool manifold allowing equal, parallel closure of flanges and joints

Features and Benefits

- ✓ Includes oil cooling system for extended use
- ✓ Solenoid valve system
- ✓ Protective frame design
- ✓ Robust hand control
- ✓ Precision, calibrated pressure gauge
- ✓ Single Tool or Multi Tool models available



Technical Information

Model	Manifold	Power Type	Power Required	Flow Rate (Low)		Flow Rate (High)		Reservoir		A		B		C		Weight Kg
				L/min	Gal/min	L/min	Gal/min	L	Gal	mm	Inch	mm	Inch	mm	Inch	
HTL-10414-110	Multi Port	Electric	110v	6.4	1.4	0.5	0.1	9	2	478	18.8	404	15.9	532	20.9	30
HTL-10414-110	Single	Electric	110v	6.4	1.4	0.5	0.1	9	2	478	18.8	404	15.9	532	20.9	30
HTL-10414-220	Multi Port	Electric	220v	6.4	1.4	0.5	0.1	9	2	478	18.8	404	15.9	532	20.9	39
HTL-10414-220	Single	Electric	220v	6.4	1.4	0.5	0.1	9	2	478	18.8	404	15.9	532	20.9	39

*All weights stated without oil.

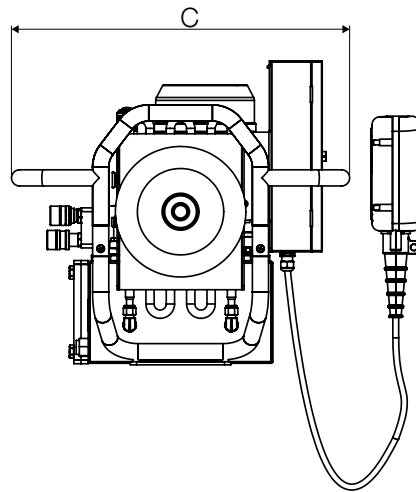
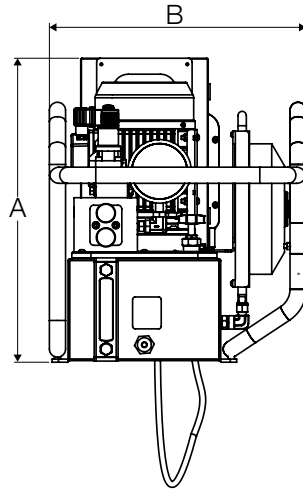

PLEASE NOTE: Figures provided are for guidance only, please refer to individual tool charts. All data is given in good faith and without acceptance of responsibility on the part of HTL.

GLOBAL EXCELLENCE IN CONTROLLED BOLTING



HTL Group Ltd
 45 Colbourne Avenue,
 Nelson Park Industrial Estate,
 Cramlington, Northumberland,
 NE23 1WD

Telephone: +44 (0) 1670 700 000
 Email: info@htlgroup.com
 Visit: www.htlgroup.com

