



3-in-1 Square Drive Attachment

The HTL Square Drive Torque Wrench Attachment is part of HTL's innovative 3-in-1 Hydraulic Torque Wrench range and works with HTL's range of 'W' Low Profile Hydraulic Torque Wrenches.

Due to its innovative design and the high quality materials used, this tool is extremely durable and easy to operate. A 360 degree, fully adjustable in-line reaction arm ensures the operator can select a reaction point to suit any application.

With square drive attachment sizes available from $\frac{3}{4}$ " to $2\frac{1}{2}$ " and torque ranges from 149 to 29,267 lbf.ft (202 to 39,681 Nm) the HTL Square Drive Torque Wrench Attachment is suitable for a wide range of applications.

Interchangeable and Cross Compatible Design

The design ensures that the operator can interchange ratchet links with many other well-known brands.

Features and Benefits

- ✓ Interchangeable with other manufacturers
- ✓ Fully adjustable 360 degree in-line reaction arm
- ✓ Push button, quick release, reversible square drive
- ✓ Fine tooth ratchet prevents locking-on
- ✓ Square drive sizes from $\frac{3}{4}$ " to $2\frac{1}{2}$ "



Technical Information

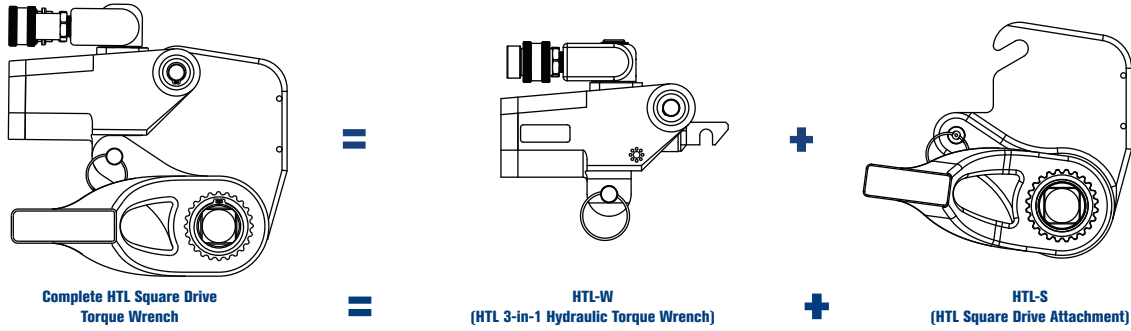

Model	HTL-S2	HTL-S4	HTL-S8	HTL-S14	HTL-S30
Torque Wrench	HTL-W2	HTL-W4	HTL-W8	HTL-W14	HTL-W30
Square Size	Inches 3/4"	1"	1 1/2"	1 1/2"	2 1/2"
Min Torque	lbf.ft	149	342	698	1246
	Nm	202	464	946	1690
Max Torque	lbf.ft	1541	3543	7562	12924
	Nm	2089	4804	10252	17522
Weight	HTL-S Kg	2.7	4.1	8.2	13.5
	HTL-W Kg	1.0	1.8	3.2	5.1
A	mm	175	212	267	311
	Inch	6.9	8.4	10.5	12.2
B	mm	160	205	254	297
	Inch	6.3	8.1	10	11.7
C	mm	48.5	65.5	80	99
	Inch	1.9	2.6	3.1	3.9
D	mm	35	38.5	50.5	58
	Inch	1.4	1.5	2.0	2.3
E	mm	60	78	110	125
	Inch	2.4	3.1	4.3	4.9
F	mm	120	148	210	220
	Inch	4.7	5.8	8.3	8.7
G	mm	85.5	110	160.5	162.5
	Inch	3.4	4.3	6.3	6.4

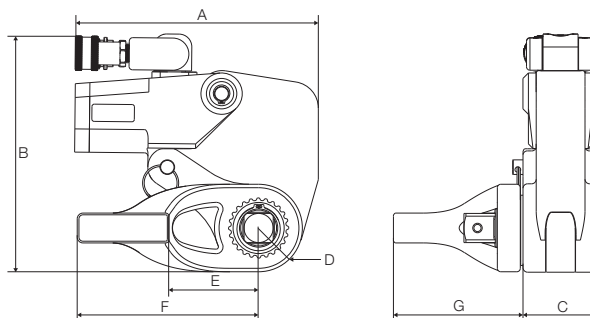

PLEASE NOTE: Figures provided are for guidance only, please refer to individual tool charts. All data is given in good faith and without acceptance of responsibility on the part of HTL.

GLOBAL EXCELLENCE IN CONTROLLED BOLTING



HTL Group Ltd
 45 Colbourne Avenue,
 Nelson Park Industrial Estate,
 Cramlington, Northumberland,
 NE23 1WD

Telephone: +44 (0) 1670 700 000
 Email: info@htlgroup.com
 Visit: www.htlgroup.com

