



TORQUE THE FUTURE!

AVVITATORI PNEUMATICI A MASSA BATTENTE MECCANICA
PNEUMATIC IMPACT WRENCHES



PNEUMATIC IMPACT WRENCHES

ERGONOMIC RELIABLE & POWERFUL



Gli avitatori pneumatici C.A.P. presentano un moderno concetto di fluidodinamica unito ad un eccezionale rapporto peso/potenza presentando sul mercato una soluzione unica nel suo genere.

C.A.P. introduces a new concept of pneumatic impact wrenches, with a modern concept of fluid dynamics combined with an exceptional weight/power ratio. An unique solution on the market.

BENEFICI

- Rapporto peso/potenza
- Flusso fluidodinamico performante
- Ampia gamma
- Affidabile, durevole e versatile
- Bassi costi di manutenzione

BENEFITS

- Excellent power/weight ratio
- Efficient fluid dynamic flow
- Wide range
- Reliable, durable and versatile
- Low maintenance costs

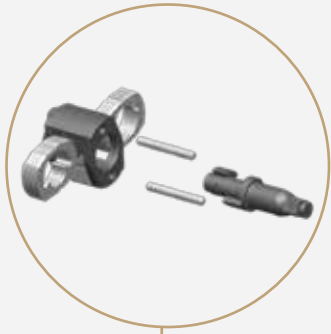

TWIN HAMMER MECHANISM

Meccanismo unico a due martelli con aumento costante della coppia. Offre un colpo bilanciato istantaneo ed è il meccanismo più potente sul mercato.

Unique mechanism for continuous torquing increase with two solid ring hammers. It delivers instantaneous balanced blow. More powerful than any other mechanism on the market.

THREE LEVER SET-UP

Nuovo switch incorporato maggiormente funzionale.

A new embedded design to prevent torque changing accidentally.



ERGONOMIC HANDLE

Materiale composito e grip sull'impugnatura ergonomica per applicazioni di lunga durata.

Composite material and ergonomic handle grip for long time operation.





3/8" - 1/2" IMPACT WRENCH

Avitatori ad impulsi 3/8" - 1/2" compatti con sistema a masse battenti a singolo martello (Jumbo) o doppio martello (Twin Hammer). Design ergonomico ed evoluta fluidodinamicità.

Compact 3/8" - 1/2" impact wrenches with single hammer (Jumbo) or Twin Hammer mechanism. Ergonomic design and advanced fluid dynamics.



IMPACT WRENCH KP88

DATI TECNICI TECHNICAL DATA

MODELLO MODEL	ATTACCO SQUARE DRIVE	CAPACITÀ BOLT RANGE	COPPIA MAX MAX TORQUE	COPPIA RACCOMDATA WORKING TORQUE	INGRESSO AIR INLET	DIMENSIONI DIMENSIONS	MECCANISMO MECHANISM
KP58	3/8"	M6 - M12	583 Nm 430 ft-lb	40 - 350 Nm 29 - 258 ft-lb	1/4" Npt	157 mm 6.18 in 1,2 kg 2.64 lbs	Twin Hammer
KP62	1/2"	M8 - M16	624 Nm 460 ft-lb	40 - 350 Nm 29 - 258 ft-lb	1/4" Npt	157 mm 16.18 in 1,2 kg 2.64 lbs	Twin Hammer
KP88	1/2"	M10 - M16	880 Nm 650 ft-lb	45 - 575 Nm 33 - 424 ft-lb	1/4" Npt	110 mm 4.33 in 1,3 kg 2.9 lbs	Jumbo

APPLICAZIONI APPLICATIONS



OFFICINA
WORKSHOPS



MANUTENZIONE INDUSTRIALE LEGGERA
LIGHT INDUSTRIAL MAINTENANCE



ASSEMBLAGGIO
ASSEMBLY



IMPACT WRENCH KP88

1/2"

IMPACT WRENCH

Avitatori ad impulsi 1/2" con sistema a masse battenti a singolo martello (Jumbo) o doppio martello (Twin Hammer). Design ergonomico ed evoluta fluidodinamicità.

1/2" impact wrenches with single hammer (Jumbo) or Twin Hammer mechanism. Ergonomic design and advanced fluid dynamics.



IMPACT WRENCH KP110

DATI TECNICI TECHNICAL DATA

MODELLO MODEL	ATTACCO SQUARE DRIVE	CAPACITÀ BOLT RANGE	COPPIA MAX MAX TORQUE	COPPIA RACCOMDATA WORKING TORQUE	INGRESSO AIR INLET	DIMENSIONI DIMENSIONS	MECCANISMO MECHANISM
KP25A	1/2"	M10 - M16	244 Nm 180 ft-lb	61 - 190 Nm 45 - 140 ft-lb	1/4" Npt	341 mm 13.4 in 1,8 kg 3.97 lbs	Jumbo
KP110	1/2"	M10 - M18	1120 Nm 826 ft-lb	70 - 800 Nm 52 - 590 ft-lb	1/4" Npt	187 mm 7.4 in 1,9 kg 4.2 lbs	Twin Hammer

APPLICAZIONI APPLICATIONS



OFFICINA
WORKSHOPS



CAMBIO GOMME
TYRE CHANGE



MANUTENZIONE INDUSTRIALE
INDUSTRIAL MAINTENANCE



INGEGNERIA CIVILE INFRASTRUTTURE
CIVIL ENGINEERING INFRASTRUCTURES



IMPACT WRENCH KP110



3/4" - 1" IMPACT WRENCH

Avitatori ad impulsi 3/4" - 1" con sistema a masse battenti a doppio martello (Twin Hammer). Design ergonomico ed evoluta fluidodinamicità.

3/4" - 1" impact wrenches with Twin Hammer mechanism. Ergonomic design and advanced fluid dynamics.



IMPACT WRENCH KP180

DATI TECNICI TECHNICAL DATA

MODELLO MODEL	ATTACCO SQUARE DRIVE	CAPACITÀ BOLT RANGE	COPPIA MAX MAX TORQUE	COPPIA RACCOMDATA WORKING TORQUE	INGRESSO AIR INLET	DIMENSIONI DIMENSIONS	MECCANISMO MECHANISM
KP180	3/4"	M12 - M22	1765 Nm 1300 ft-lb	270 - 1500 Nm 199 - 1106 ft-lb	3/8" Npt	222 mm 8.7 in 3,7 kg 8.2 lbs	Twin Hammer
KP190	3/4"	M14 - M24	2050 Nm 1512 ft-lb	270 - 1630 Nm 199 - 1202 ft-lb	3/8" Npt	220 mm 8.7 in 3,4 kg 7.5 lbs	Twin Hammer
KP240	1"	M18 - M36	3428 Nm 2530 ft-lb	520 - 2120 Nm 383 - 1570 ft-lb	1/2" Npt	275 mm 10.8 in 7,4 kg 16.3 lbs	Twin Hammer
KP240L	1"	M18 - M36	3428 Nm 2530 ft-lb	520 - 2120 Nm 383 - 1570 ft-lb	1/2" Npt	416 mm 16.3 in 8,3 kg 18.3 lbs	Twin Hammer

APPLICAZIONI APPLICATIONS



OFFICINA
WORKSHOPS



CAMBIO GOMME
TYRE CHANGE



MANUTENZIONE INDUSTRIALE
INDUSTRIAL MAINTENANCE



MANUTENZIONE SU MEZZI AGRICOLI
MAINTENANCE ON AGRICULTURAL MACHINES



MOVIMENTO TERRA
EARTH MOVING



FERROVIARIO
RAILWAYS



INGEGNERIA CIVILE INFRASTRUTTURE
CIVIL ENGINEERING INFRASTRUCTURES



IMPACT WRENCH KP180

ACCESSORI

ACCESSORIES

Alla linea di utensili dedicata, affianchiamo una gamma completa di chiavi a bussola, barre di torsione e accessori per uso professionale.

In addition to the dedicated tool line, we also offer a complete range of impact socket, torque bars and accessories for professional use.



IMPACT SOCKETS

ACCESSORI

ACCESSORIES



BUSSOLE
IMPACT SOCKETS



BARRE DI TORSIONE
TORQUE SOCKETS



TUBO PNEUMATICO
PNEUMATIC HOSE



KIT RESCA
KIT RESCA



CARRELLO
TROLLEY



IMPACT WRENCH KP190



IMPACT WRENCH KP240L

CHI SIAMO ABOUT US

C.A.P. srl è un'azienda specializzata nell'engineering e nella produzione di avvitatori idraulici, pneumatici, macchine Multienergy e attrezzature per il settore industriale ed automotive.

Nasce nel 1974 come azienda produttrice di avvitatori pneumatici, negli anni '80 sviluppa una gamma di avvitatori idraulici ad impulsi ad alte prestazioni per soddisfare le numerose richieste provenienti dal mercato industriale italiano.

Nel 2000 C.A.P. progetta una soluzione innovativa per l'assistenza su strada, creando una gamma completa di macchine Multienergy che forniscono contemporaneamente aria compressa ed energia elettrica.

La qualità, la velocità, la potenza e la precisione della coppia di serraggio diventano i punti di forza di C.A.P. che le consentono di aprirsi con successo al mercato internazionale.

I valori che condividiamo in C.A.P. sono la passione, la dedizione, la responsabilità e il costante impegno.

In C.A.P. crediamo profondamente nell'espansione della nostra attività a livello globale, concentrando il nostro successo nell'evoluzione delle nostre soluzioni e nel rafforzamento del nostro ruolo strategico con i nostri partner.

C.A.P. srl is specialized in the engineering and production of hydraulic impact wrenches, air impact wrenches, Multienergy machines and equipment for the industrial and automotive sectors.

It originated in 1974 as a manufacturer of air impact wrenches; in the '80s it developed a range of high performance hydraulic impact wrenches to meet the many requests of the Italian industrial market.

In the year 2000 C.A.P. designs an innovative solution for roadside assistance, creating a complete range of Multienergy machines that simultaneously supply compressed air and electricity.

The quality, speed, power and precision of the tightening torque become the strong points of C.A.P. which translate into success on the international markets.

At C.A.P., we share passion, dedication, responsibility and constant commitment.

We strongly believe in expanding our business at global level, focusing our success on evolving our solutions and strengthening our strategic role with our partners.

SERVIZI SERVICES



CONSULENZA
TRAINING



MANUTENZIONE
MAINTENANCE



NOLEGGIO
RENTAL

Per maggiori informazioni su C.A.P. e per scoprire in dettaglio tutti i nostri prodotti e servizi visita il nostro sito caphydraulic.com.

For more information or details about our range of products, please visit our website caphydraulic.com.



C.A.P. srl

Via Dante Alighieri 58 E
42023 Cadelbosco di Sopra
Reggio Emilia, Italia

phone +39 0522 917 633

fax +39 0522 917 356

info@caphydraulic.com
caphydraulic.com

