



Hydroseal

Series 3500

Pilot Operated Relief Valves



Superior Pressure Relief Products

Hydroseal Series 3500 Pilot Operated Relief Valve

The Hydroseal Series 3500 is a high performance pilot operated safety relief valve that is offered in both Modulating and Snap action. Useful for air, gas, mixed phase and liquid services, these valves are designed for reliable operation, long seat life and easy low cost field service. The Series 3500 product line is offered in a wide range of orifices, materials, pressures and temperature ranges.

General Design Features

• Proven Soft Seat Design:

Hydroseal's unique captured o-ring design used across many of our other product lines allows many different Elastomers to be offered at the lowest cost possible. Using standard size o-rings also allows for easy replacement.

• **Seat Tightness:** The difference in area of the dome side and the seat side of the piston keeps the main valve bubble tight right up to the set pressure. Pilot valves are an excellent choice for applications with operating pressures very close to set pressure.

• **Snap Action:** The snap action control pilot fully opens the main valve at set pressure achieving full capacity until the reseal point is reached and the main valve closes. The snap pilot has an adjustable blowdown and is built for minimal maintenance and easy repair. Standard for air and gas only.

• **Modulating Action:** Ideal for applications where a minimal amount of product loss is critical. The modulating control pilot gradually opens and closes the main valve to relieve only the excess pressure in a system. It will fully open the main valve before 10% overpressure is reached. Standard for liquid and optional for air and gas.

• **Easy Repair:** All seals are o-rings that are easily replaced and are offered in a wide array of materials such as Fluorocarbon, Nitrile and PTFE. The main valve's bolted construction allows for easy disassembly.

• **Orifice Areas:** All orifice sizes meet or exceed competitor's dimensions for easy interchangeable replacement.

• **API Dimensions:** Main valve centerline to face dimensions meet API 526.

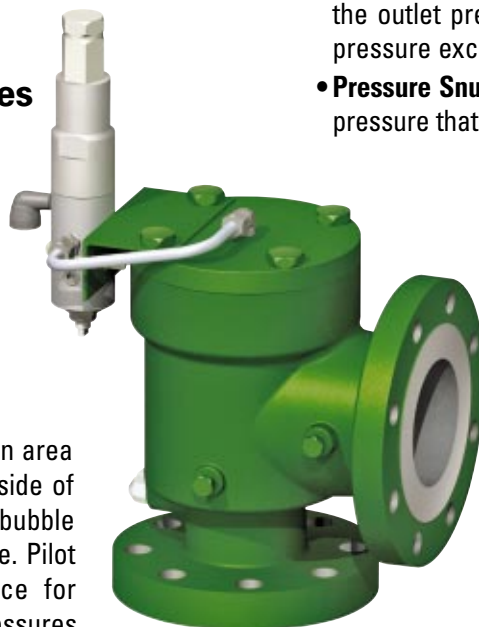

Accessories

• **Field Test Connection:** Allows for in service testing of the valve by charging the pilot through a test port reducing maintenance and system down time.

• **Back-Flow Preventer:** Prevents backpressure on the main valve outlet from opening the main valve by allowing the outlet pressure to charge the dome when the back pressure exceeds the inlet pressure.

• **Pressure Snubber:** Filters out pressure spikes in the inlet pressure that can cause the main valve to pop early.

• **Filter:** Recommended for extra dirty service that could cause blockages or wear to the control pilot valve.

• **Lift Lever:** Another option for in service testing. By lifting a handle, the control pilot is opened thereby opening the main valve until the handle is released.

• **Remote Sensing:** Allows the set pressure signal to come from somewhere other than the inlet of the main valve. By leaving the sense line off the pilot valve and plugging the pitot, the end user can plumb the supply pressure from a different location.

Size & Range

Inlet x Outlet	Orifice	Nozzle Diameter		Nozzle Area		Lift	Max. Pressure
		in.	cm	in. ²	cm ²		
1 x 2	D	0.437	1.11	0.150	0.97	0.350 in. 8.89 cm	6170 psi(g) 425.5 bar(g)
	E	0.560	1.42	0.246	1.59		
	F	0.688	1.75	0.372	2.40		
1 1/2 x 2	D	0.437	1.11	0.150	0.97	0.572 in. 14.53 cm	
	E	0.560	1.42	0.246	1.59		
	F	0.688	1.75	0.372	2.40		
1 1/2 x 3	G	0.871	2.21	0.596	3.84	0.703 in. 17.86 cm	
	H	1.125	2.86	0.994	6.41		
	J	1.382	3.51	1.500	9.68		
2 x 3	J	1.382	3.51	1.500	9.68	1.049 in. 26.64 cm	
	K	1.653	4.20	2.146	13.85		
	L	2.063	5.24	3.343	21.57		
3 x 4	L	2.063	5.24	3.343	21.57	1.590 in. 40.39 cm	
	M	2.314	5.88	4.206	27.14		
	N	2.537	6.44	5.054	32.61		
	P	3.125	7.94	7.670	49.48		
6 x 8	Q	4.060	10.31	12.946	83.52	2.484 in. 63.09 cm	1480 psi(g) 102.1 bar(g)
	R	4.882	12.40	18.719	120.77		
8 x 10	T	6.257	15.89	30.748	198.38	3.183 in. 80.85 cm	900 psi(g) 62.1 bar(g)



Hydroseal Series 3500 Operation, Snap & Modulating Action

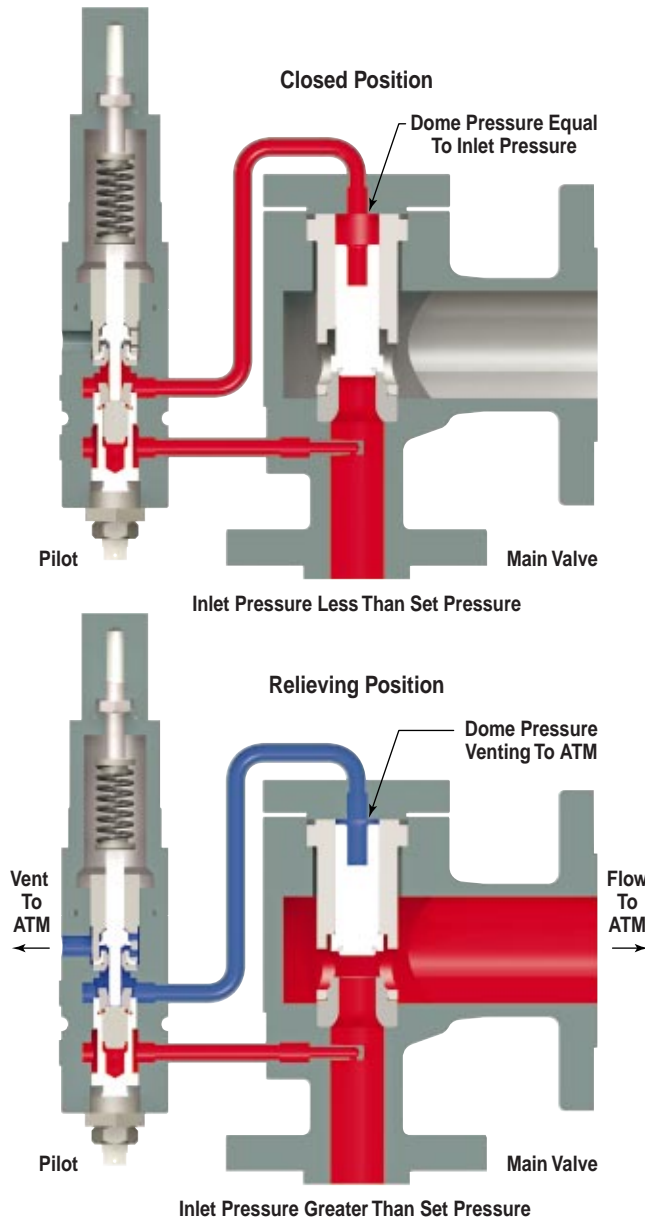

Snap Action Pilot

Below Set Pressure: The pilot allows the inlet pressure to pass through and charge the dome of the main valve keeping the main valve seat tightly closed.

Above Set Pressure: The pilot upper seat lifts fully venting the dome pressure to atmosphere allowing the main valve piston to rise opening the main valve. Simultaneously, the pilot lower seat closes keeping the inlet pressure from the main valve from re-charging the dome. When the inlet pressure drops to the reset point, the pilot lower seat opens and the pilot upper seat closes, recharging the dome and closing the main valve.

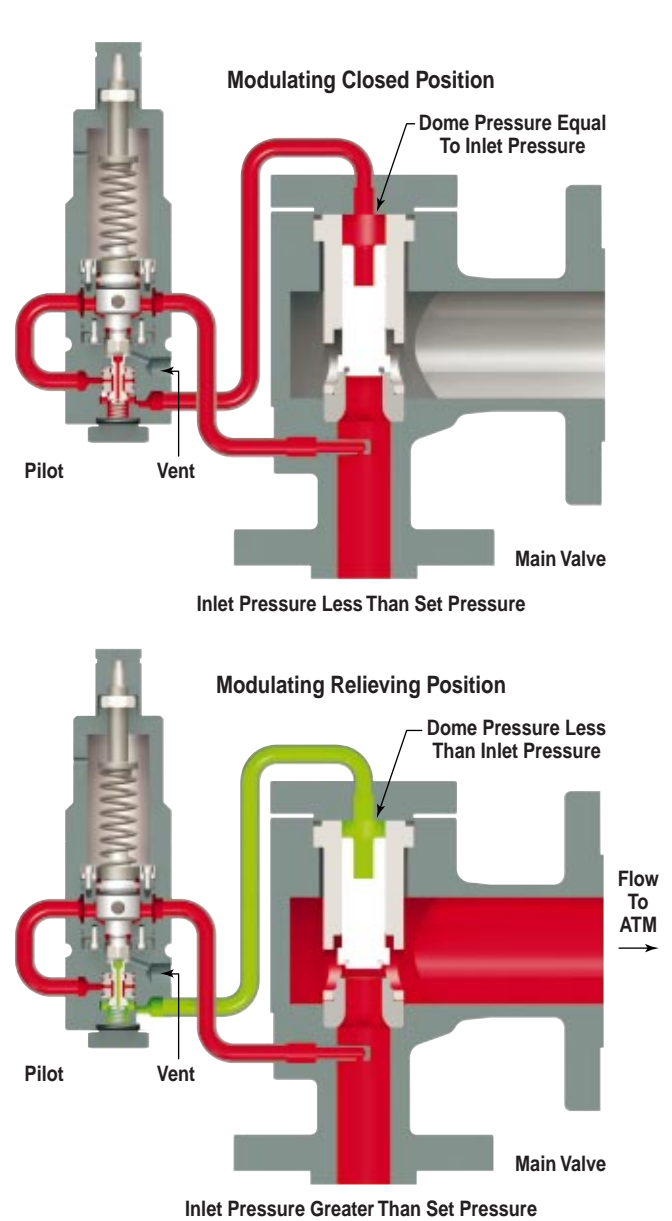

Modulating Action Pilot

Below Set Pressure: The pilot allows the inlet pressure to pass through and charge the dome of the main valve keeping the main valve seat tightly closed.

Above Set Pressure: The modulating pilot allows the dome pressure to be vented gradually in proportion with the increase in inlet pressure. As the inlet pressure increases from 100% to 110% of set pressure, the main valve goes from closed to full open. As the system pressure drops below the set pressure, the modulating pilot gradually recharges the dome of the main valve in proportion with the drop in system pressure, closing the main valve.



Hydroseal Series 3500, Weights & Dimension Data

Orifice	Inlet x Outlet	Class	Max. Set	Dimensions (in.)			Weight (approx.)	
				A	B	C	lbs.	kg
D API Area .110 in. ² / .71 cm ² Actual Area .150 in. ² / .97 cm ²	1 x 2	150 x 150	285	4.12	4.50	14.50	24	10.9
	1 x 2	300 x 150	740	4.37	4.50	14.62	26	11.8
	1 x 2	600 x 150	1480	4.37	4.50	14.62	26	11.8
	1 x 2	900/1500 x 300	3705	4.93	4.75	15.25	32	14.5
	1 x 2	2500 x 300	6170	4.93	4.75	15.25	35	15.9
	1 1/2 x 2	150 x 150	285	4.87	4.75	15.00	26	11.8
	1 1/2 x 2	300 x 150	740	4.87	4.75	15.00	30	13.6
	1 1/2 x 2	600 x 150	1480	4.87	4.75	15.00	30	13.6
	1 1/2 x 2	900/1500 x 300	3705	5.87	5.50	16.25	40	18.2
	1 1/2 x 2	2500 x 300	6170	5.87	5.50	16.25	50	22.7
E API Area .196 in. ² / 1.27 cm ² Actual Area .249 in. ² / 1.59 cm ²	1 x 2	150 x 150	285	4.12	4.50	14.50	24	10.9
	1 x 2	300 x 150	740	4.37	4.50	14.62	26	11.8
	1 x 2	600 x 150	1480	4.37	4.50	14.62	26	11.8
	1 x 2	900/1500 x 300	3705	4.93	4.75	15.25	32	14.5
	1 x 2	2500 x 300	6170	4.93	4.75	15.25	35	15.9
	1 1/2 x 2	150 x 150	285	4.87	4.75	15.00	26	11.8
	1 1/2 x 2	300 x 150	740	4.87	4.75	15.00	30	13.6
	1 1/2 x 2	600 x 150	1480	4.87	4.75	15.00	30	13.6
	1 1/2 x 2	900/1500 x 300	3705	5.87	5.50	16.25	40	18.2
	1 1/2 x 2	2500 x 300	6170	5.87	5.50	16.25	50	22.7
F API Area .370 in. ² / 1.98 cm ² Actual Area .372 in. ² / 2.40 cm ²	1 x 2	150 x 150	285	4.12	4.50	14.50	24	10.9
	1 x 2	300 x 150	740	4.37	4.50	14.62	26	11.8
	1 x 2	600 x 150	1480	4.37	4.50	14.62	26	11.8
	1 x 2	900/1500 x 300	3705	4.93	4.75	15.25	32	14.5
	1 x 2	2500 x 300	6170	4.93	4.75	15.25	35	15.9
	1 1/2 x 2	150 x 150	285	4.87	4.75	15.00	26	11.8
	1 1/2 x 2	300 x 150	740	4.87	4.75	15.00	30	13.6
	1 1/2 x 2	600 x 150	1480	4.87	4.75	15.00	30	13.6
	1 1/2 x 2	900/1500 x 300	3705	5.87	5.50	16.25	40	18.2
	1 1/2 x 2	2500 x 300	6170	5.87	5.50	16.25	50	22.7
G API Area .503 in. ² / 3.25 cm ² Actual Area .596 in. ² / 3.84 cm ²	1 1/2 x 3	150 x 150	285	5.12	4.87	16.12	58	26.4
	1 1/2 x 3	300 x 150	740	5.12	4.87	16.12	61	27.7
	1 1/2 x 3	600 x 150	1480	5.12	4.87	16.12	61	27.7
	1 1/2 x 3	900/1500 x 300	3705	6.37	6.75	18.62	95	43.2
	1 1/2 x 3	2500 x 300	6170	6.37	6.75	18.62	104	47.3
	2 x 3	150 x 150	285	5.37	4.87	16.87	59	26.8
	2 x 3	300 x 150	740	5.37	4.87	16.87	62	28.2
	2 x 3	600 x 150	1480	5.37	4.87	16.87	62	28.2
	2 x 3	900/1500 x 300	3705	6.56	6.75	18.87	103	46.8
	2 x 3	2500 x 300	6170	7.00	6.75	19.25	115	52.3
H API Area .785 in. ² / 5.06 cm ² Actual Area .994 in. ² / 6.41 cm ²	1 1/2 x 3	150 x 150	285	5.12	4.87	16.12	58	26.4
	1 1/2 x 3	300 x 150	740	5.12	4.87	16.12	61	27.7
	1 1/2 x 3	600 x 150	1480	5.12	4.87	16.12	61	27.7
	1 1/2 x 3	900/1500 x 300	3705	6.37	6.75	18.62	95	43.2
	1 1/2 x 3	2500 x 300	6170	6.37	6.75	18.62	104	47.3
	2 x 3	150 x 150	285	5.37	4.87	16.87	59	26.8
	2 x 3	300 x 150	740	5.37	4.87	16.87	62	28.2
	2 x 3	600 x 150	1480	5.37	4.87	16.87	62	28.2
	2 x 3	900/1500 x 300	3705	6.56	6.75	18.87	103	46.8
	2 x 3	2500 x 300	6170	7.00	6.75	19.25	115	52.3



Hydroseal Series 3500, Weights & Dimension Data

Orifice	Inlet x Outlet	Class	Max. Set	Dimensions (in.)			Weight (approx.)	
				A	B	C	lbs.	kg
J API Area 1.287 in. ² / 8.30 cm ² Actual Area 1.500 in. ² / 9.68 cm ²	2 x 3	150 x 150	285	5.37	4.87	16.87	59	26.8
	2 x 3	300 x 150	740	5.37	4.87	16.87	62	28.2
	2 x 3	600 x 150	1480	5.37	4.87	16.87	62	28.2
	2 x 3	900/1500 x 300	3705	6.56	6.75	18.87	103	46.8
	2 x 3	2500 x 300	6170	7.00	6.75	19.25	115	52.3
	3 x 4	150 x 150	285	6.12	6.37	18.12	100	45.5
	3 x 4	300 x 150	740	6.12	6.37	18.12	106	48.2
	3 x 4	600 x 150	1480	6.37	6.37	18.12	106	48.2
	3 x 4	900 x 300	2220	7.50	7.12	20.00	141	64.1
	3 x 4	1500 x 300	3705	7.50	7.12	20.00	153	69.5
K API Area 1.838 in. ² / 11.86 cm ² Actual Area 2.146 in. ² / 13.85 cm ²	3 x 4	150 x 150	285	6.12	6.37	18.12	100	45.5
	3 x 4	300 x 150	740	6.12	6.37	18.12	106	48.2
	3 x 4	600 x 150	1480	6.37	6.37	18.12	106	48.2
	3 x 4	900 x 300	2220	7.50	7.12	20.00	141	64.1
	3 x 4	1500 x 300	3705	7.50	7.12	20.00	153	69.5
L API Area 2.853 in. ² / 18.41 cm ² Actual Area 3.343 in. ² / 21.57 cm ²	3 x 4	150 x 150	285	6.12	6.37	18.12	100	45.5
	3 x 4	300 x 150	740	6.12	6.37	18.12	106	48.2
	3 x 4	600 x 150	1480	6.37	6.37	18.12	106	48.2
	3 x 4	900 x 300	2220	7.50	7.12	20.00	141	64.1
	3 x 4	1500 x 300	3705	7.50	7.12	20.00	153	69.5
	4 x 6	150 x 150	285	7.75	8.25	21.37	184	83.6
	4 x 6	300 x 150	740	7.75	8.25	21.37	192	87.3
	4 x 6	600 x 150	1480	7.75	8.25	21.37	202	91.8
	4 x 6	900 x 300	2220	9.81	9.18	24.00	285	129.5
	4 x 6	1500 x 300	3705	9.81	9.18	24.00	300	136.4
M API Area 3.600 in. ² / 23.23 cm ² Actual Area 4.206 in. ² / 27.41 cm ²	4 x 6	150 x 150	285	7.75	8.25	21.37	184	83.6
	4 x 6	300 x 150	740	7.75	8.25	21.37	192	87.3
	4 x 6	600 x 150	1480	7.75	8.25	21.37	202	91.8
	4 x 6	900 x 300	2220	9.81	9.18	24.00	285	129.5
	4 x 6	1500 x 300	3705	9.81	9.18	24.00	300	136.4
N API Area 4.340 in. ² / 28.00 cm ² Actual Area 5.054 in. ² / 32.61 cm ²	4 x 6	150 x 150	285	7.75	8.25	21.37	184	83.6
	4 x 6	300 x 150	740	7.75	8.25	21.37	192	87.3
	4 x 6	600 x 150	1480	7.75	8.25	21.37	202	91.8
	4 x 6	900 x 300	2220	9.81	9.18	24.00	285	129.5
	4 x 6	1500 x 300	3705	9.81	9.18	24.00	300	136.4
P API Area 6.380 in. ² / 41.16 cm ² Actual Area 7.670 in. ² / 49.48 cm ²	4 x 6	150 x 150	285	7.75	8.25	21.37	184	83.6
	4 x 6	300 x 150	740	7.75	8.25	21.37	192	87.3
	4 x 6	600 x 150	1480	7.75	8.25	21.37	202	91.8
	4 x 6	600 x 300	1480	9.81	9.18	24.00	276	125.5
	4 x 6	900 x 300	2220	9.81	9.18	24.00	285	129.5
Q API Area 11.050 in. ² / 71.29 cm ² Actual Area 12.946 in. ² / 83.52 cm ²	4 x 6	1500 x 300	3705	9.81	9.18	24.00	300	136.36
	6 x 8	150 x 150	285	9.43	9.50	25.62	352	160.0
	6 x 8	300 x 150	740	9.43	9.50	25.62	369	167.7
	6 x 8	600 x 150	1480	9.68	9.50	25.87	394	179.1
	6 x 8	150 x 150	285	9.43	9.50	25.62	352	160.0
R API Area 16.000 in. ² / 103.23 cm ² Actual Area 18.719 in. ² / 120.77 cm ²	6 x 8	300 x 150	740	9.43	9.50	25.62	369	167.7
	6 x 8	600 x 150	1480	9.68	9.50	25.87	394	179.1
	6 x 8	150 x 150	285	9.43	9.50	25.62	352	160.0
T API Area 26.000 in. ² / 167.74 cm ² Actual Area 30.748 in. ² / 198.38 cm ²	8 x 10	150 x 150	285	10.87	11.00	27.37	511	232.3
	8 x 10	300 x 150	740	10.87	11.00	27.37	534	242.7
	8 x 10	600 x 150	900	11.68	11.00	28.12	575	261.4



Hydroseal Series 3500, Parts List & Materials

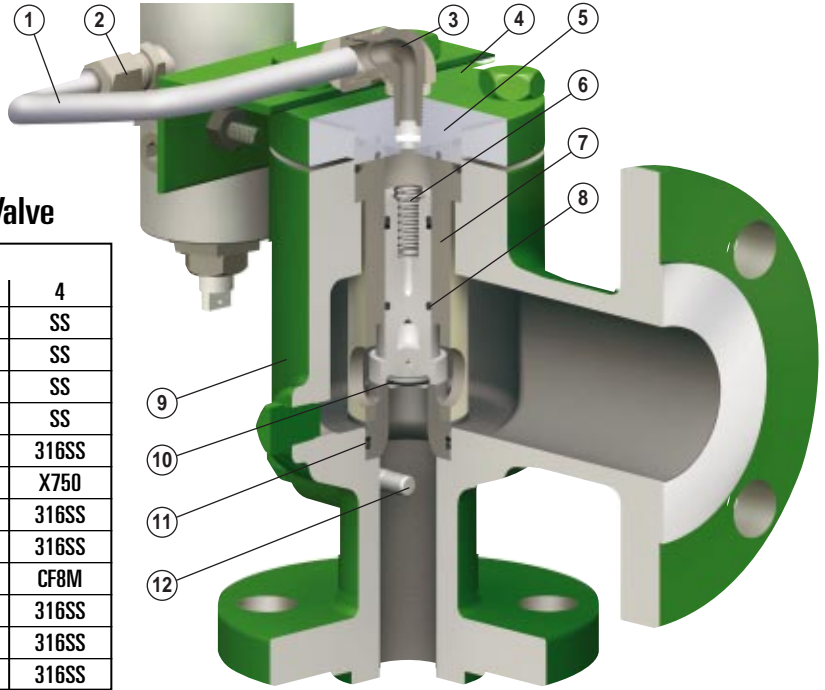

Parts List & Materials, Series 3500 Relief Valve

Index	Description	Material			
		0	2	3	4
1	Tube	SS	SS	SS	SS
2	Tube Fitting Straight	CS	CS	SS	SS
3	Tube Fitting 90	CS	CS	SS	SS
4	Bracket	CS	CS	SS	SS
5	Bonnet	SA36	SA36	316SS	316SS
6	Return Spring	316SS	X750	316SS	X750
7	Guide	17-4 PH	17-4 PH	316SS	316SS
8	Piston	316SS	316SS	316SS	316SS
9	Body	WCB	WCB	CF8M	CF8M
10	O-Ring Retainer	316SS	316SS	316SS	316SS
11	Nozzle	316SS	316SS	316SS	316SS
12	Pitot	316SS	316SS	316SS	316SS

Parts List & Materials Snap Action Pilot

Index	Description	Material
1	Cap	316SS
2	Adjusting Screw	316SS
3	Pilot Bonnet	316SS
4	Top Adaptor	316SS
5	Spring	316SS*
6	Lower Spring Plate	316SS
7	Disc	316SS
8	Pilot Disc Guide	316SS
9	Pilot Body	316SS
10	Pilot Seat Cap	316SS
11	Pilot Nozzle	316SS
12	Pilot Nozzle Seal	Gasket Material
13	Blowdown Seat	316SS
14	Blowdown Shuttle	316SS
15	Blowdown Adjustment Housing	316SS
16	Blowdown Adjustment Nut	316SS

*Inconel® X750 spring used for material codes 2 & 4.

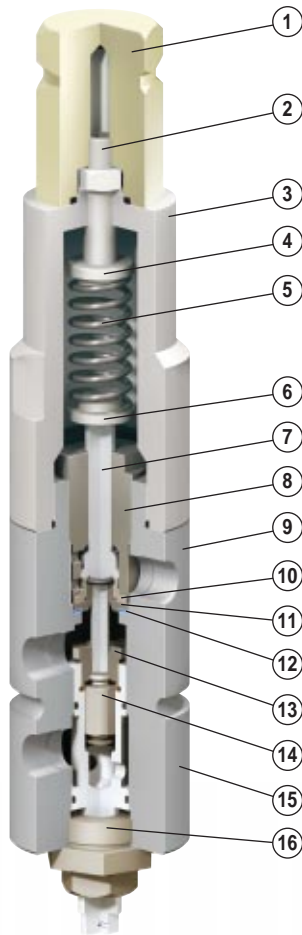

Parts List & Materials Modulating Action Pilot

Index	Description	Material
1	Cap	316SS
2	Adjusting Screw	316SS
3	Pilot Bonnet	316SS
4	Top Adaptor	316SS
5	Spring	316SS*
6	Body	316SS
7	Large Clamp Ring	316SS
8	Upper Diaphragm	Viton®
9	Input Module Body	316SS
10	Stop Pin	316SS
11	Input Spindle	316SS
12	Lower Diaphragm	Viton®
13	Small Clamp Ring	316SS
14	Ball Holder	316SS
15	Ball	316SS
16	Control Module Body	316SS
17	Control Spindle	316SS
18	Control Spring	Inconel® X750
19	Spring Nut	316SS

*Inconel® X750 spring used for material codes 2 & 4.

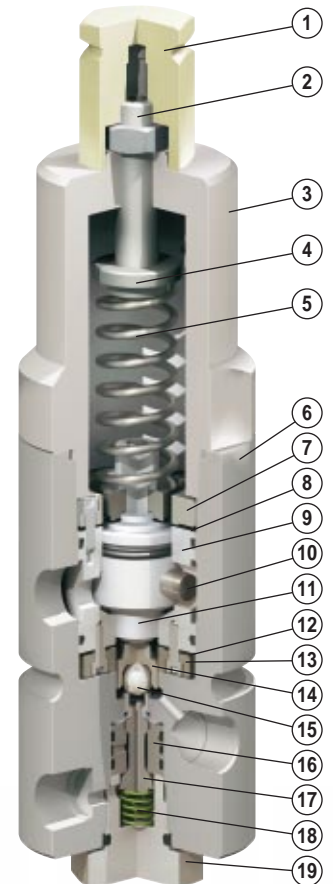

Hydroseal Series 3500, Parts Number Codes & Engineering Data

Type	S • Snap (Air/Gas Only) M • Modulating (Air/Gas & Liquid)		
Seat Material	C • Neoprene	K • Kalrez	T • Teflon®
	E • EPDM	N • Nitrile	V • Viton®
Inlet Size	1 • 1"	2 • 2"	4 • 4"
	A • 1.5"	3 • 3"	6 • 6"
Orifice	D • D	H • H	M • M
	E • E	J • J	N • N
	F • F	K • K	P • P
	G • G	L • L	T • T
Outlet Size	2 • 2"	4 • 4"	8 • 8"
	3 • 3"	6 • 6"	10 • 10"
Flange Class	A • 150 x 150	C • 600 x 150	E • 1500 x 300
	B • 300 x 150	D • 900 x 300	F • 2500 x 300
Facing	1 • RF x RF	2 • RTJ x RF	3 • RTJ x RTJ
	0 • CS Std.	3 • SS Std.	
Material	2 • CS NACE	4 • SS NACE	
	B • Backflow Preventer	F • Filter	S • Snubber
Options*	L • Lift Lever	U • Unloader	
	Consult Factory for Spring Chart.		
Spring Range	*Multiple options can be selected.		

Temperature Limits

Temperature	Seat Material					
	Nitrile	EPDM	Viton®	Neoprene	Kalrez	Teflon®
Lower °F	-65	-70	-15	-45	30	-300
Upper °F	225	300	400	300	550	400

Sizing Equations

US Units

Air/Gas

$$W = CK_d AP_1 \sqrt{\frac{M}{TZ}}$$

Liquid

$$Q = 38K_d K_v A \sqrt{\frac{P_1 - P_d}{G}}$$

Where

$$P_1 = 1.1 P_{set} + 14.7 \text{ Over } 30 \text{ psi}$$

Or

$$P_1 = P_{set} + 17.7 \text{ Under } 30 \text{ psi}$$

$$C = 520 \sqrt{k \left(\frac{2}{k+1} \right)^{\frac{k+1}{k-1}}}$$

W = Capacity in lbm/hr

P_{set} = Set Pressure in psig

P_d = Discharge Pressure

A = Orifice Area

K_d = .878 for Air/Gas

K_d = .784 for Liquid

K_v = Viscosity Correction Factor

Q = Capacity in GPM

Z = Compressibility Factor

T = Temperature in °R

k = Ratio of Specific Heats

M = Molecular Weight

G = Specific Gravity

SI Units

Air/Gas

$$W = 13160 CK_d AP_1 \sqrt{\frac{M}{TZ}}$$

Liquid

$$Q = \frac{K_d K_v A}{11.78} \sqrt{\frac{P_1 - P_d}{G}}$$

Where

$$P_1 = 1.1 P_{set} + 101.3 \text{ Over } 207 \text{ kPa}$$

Or

$$P_1 = P_{set} + 122 \text{ Under } 207 \text{ kPa}$$

$$C = 520 \sqrt{k \left(\frac{2}{k+1} \right)^{\frac{k+1}{k-1}}}$$

W = Capacity in kg/hr

P_{set} = Set Pressure in kPag

P_d = Discharge Pressure

A = Orifice Area

K_d = .878 for Air/Gas

K_d = .784 for Liquid

K_v = Viscosity Correction Factor

Q = Capacity in liter/min

Z = Compressibility Factor

T = Temperature in °K

k = Ratio of Specific Heats

M = Molecular Weight

G = Specific Gravity



Worldwide Sales Offices



Hydroseal, a leading brand of KF Industries, reaches into every corner of the globe serving the oil & gas and industrial marketplace. Supplying an extensive range of product offerings through a worldwide network of manufacturer representatives and distributors, Hydroseal is the right choice for all your pressure relief needs.

World Headquarters

Hydroseal
1500 S.E. 89th Street
Oklahoma City, OK 73149 USA
Phone: (405) 631-1533
Fax: (405) 631-5034
E-mail: sales@circorenergy.com
www.circorenergy.com

Local Representative

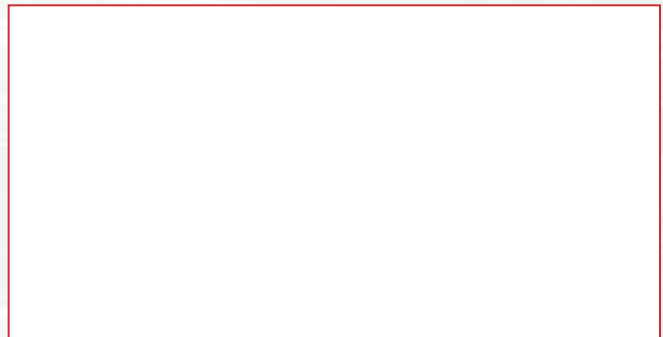

Registered to the ISO 9001
Quality System Standard,
accredited by U.K., Dutch
and German qualifying
authorities.



www.circorenergy.com